



UNILUX
HVAC INDUSTRIES

Vertical Stack Heat Pumps: Installation, Operation, and Maintenance Manual



Refrigerant
Safety Group
A2L

L Series REV-01
Published April 2026

Table of Contents

Part 1: Vertical Stack Heat Pump Catalog

| | |
|--|----|
| Product Portfolio | |
| Overview | 4 |
| Product Line Up | 5 |
| Nomenclature Key | 6 |
| Features, Options, Accessories | |
| Controls | 8 |
| Return Air Panels (Access Panels) | 9 |
| Supply Air Grilles/Registers | 10 |
| Filters | 10 |
| Ratings and Listings | |
| Performance Data /Electrical Ratings | 11 |
| Sound / Power Data | 15 |
| Fan Curves | 17 |
| Copper Riser Sizing, Insulation, Expansion | 19 |
| Submittal Data | |
| Cabinet Dimensions | 20 |
| Airflow & Riser Configurations | 23 |

Part 2: Installation, Operation, and Maintenance

| | |
|---|----|
| General Safety Guidelines | 26 |
| General Heat Pump Information | 28 |
| Receipt, Storage, and Inspection | 29 |
| Installation | 30 |
| Heat Pump Pre-Commissioning Checklist | 36 |
| Operating Limits | 37 |
| General Operations | |
| Commax Wall Pad | 39 |
| Sequence of Operations | 45 |
| Wiring Diagrams | 48 |
| Alarms - All Models | 52 |
| Timers and Interlocks | 53 |
| ERV Operation | 54 |
| Information on Servicing | 55 |
| Maintenance | 57 |
| Warranty Information | 59 |

Part 1:
Vertical Stack Heat Pump
Catalog

Product Portfolio

Vertical Stack Heat Pumps Overview

Our product line of vertical stack heat pumps consists of three versatile unit types that are energy-efficient and whisper-quiet for resident comfort; water source, hydronic heating hybrid, and geothermal applications. All heat pump cabinets are designed for concealed installation with sound insulation for quiet operation. All Unilux HVAC vertical stack heat pumps can be outfitted with our integrated HRV/ERV systems to meet fresh air building codes and increase resident comfort and energy savings.

High-Rise Residential Application

Unilux HVAC is known for providing residents whisper-quiet comfort with our state-of-the-art heat pumps. We use energy efficient ECM motors in all our vertical stack heat pumps. We offer a line of sleek return air panels, supply air grilles, and accessories that blend in seamlessly to high-end residential projects.

Flexible Engineering

We offer various configurations for motor/blower assemblies, riser locations and insulation, hot water coil assembly, and more to ensure our heat pumps perfectly match your specifications. Our comprehensive controls offering makes operating the heat pump a breeze for your residents.

Simple Installation

Unilux HVAC heat pumps are factory assembled in accordance with the approved shop drawings. Risers are factory installed and sized to suit job specifications.

Easy Maintenance

Filters are easily changed through the return air panel. The chassis is completely removable.

Quality and Safety

Every heat pump is factory tested before shipping and ETL listed.

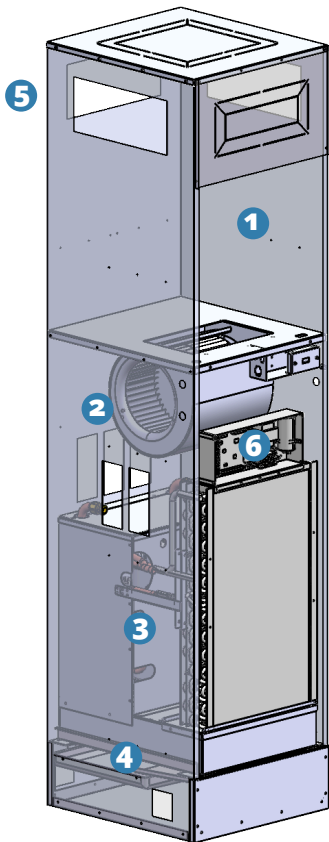

Standard Features—All Models

1. Cabinet

20-gauge steel cabinet with ½-inch fiberglass insulation and thermosetting resin.

2. Motor/Blower Assembly

Multi-speed ECM mounted to a centrifugal fan with a galvanized steel forward-curved DWDI wheel.

3. Refrigeration Chassis

Completely removable chassis with isolated compressor to minimize vibration and noise.

4. Drain Pan and Overflow Sensor

Easy to access removable stainless steel drain pan with overflow sensor to detect rising water levels and turn off unit to prevent leaks.

5. Risers (Not Shown)

Supply and return risers are type 'L' copper and condensate risers are type 'DWV'. Insulation is provided as per specifications.

6. Control Board

Standard and optional controls include; overflow sensor, freeze protection sensor, dynamic balancing, and advanced diagnostics. Compatible with most thermostats.

Product Portfolio

Product Line Up

Vertical Stack Heat Pump Cabinet

Unilux HVAC builds standardized cabinets that suit our entire vertical stack product line. Cabinets are designed for concealed installation and are insulated for whisper-quiet comfort. Heat pump cabinets are constructed with 20-gauge steel and can be configured with front, back, left, right, or top supply air openings. Once installed, the return air panel, supply air grille, and thermostat are all that is visible inside the suite. Maintenance is easily performed through the return air panel and the chassis can be removed through the opening.



1. Water Source Heat Pump

Unilux HVAC's signature heat pump is designed for residential applications, combining peak energy efficiency and low upfront costs. Water source heat pumps operate on a closed water loop that either extracts heat from the loop and disperses it throughout the suite to provide heating, or absorbs heat from the suite and expels it back to the loop to provide cooling. This provides on-demand heating and cooling year-round, with each heat pump operating independently of each other.

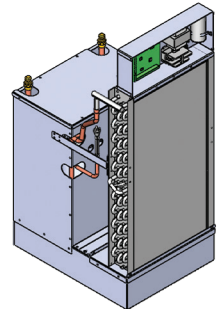

2. Hybrid Heat Pump

Our Hybrid Vertical Stack Heat Pump unites the cooling power of a heat pump with the heating efficiency of a fan coil. Cooling is achieved through the combination of DX coil and compressor circuit. Heating is provided by an efficient hot water coil that is connected to building wide hot water riser system. The air flows through the coils and gets distributed throughout suite space by an ECM fan. Hydronic heating is more energy efficient than using a compressor and provides reliability with less mechanical maintenance.

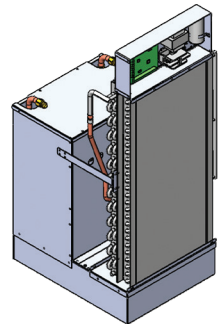

3. Geothermal Heat Pump

Geothermal heat pumps are among the most energy efficient options on the market, providing savings in operational costs. Unilux HVAC manufactures ground source heat pumps which use a closed loop of fluid running underground. To provide heating to your suite, this loop harvests heat energy from the earth and carries it to your heat pump, where it is then concentrated into usable heating for your suite via a compressor. To provide cooling, the process is reversed and the heat pump extracts heat from your suite and carries it back into the ground.

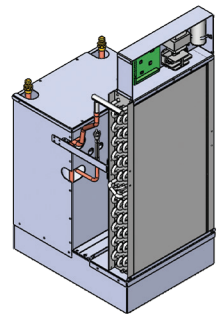

4. Integrated ERV

Unilux HVAC has developed a patented energy recovery ventilation system (ERV) that can be integrated with our full line of vertical stack heat pumps. HRV products have been used for years to introduce fresh air into homes and minimize energy loss by utilizing a heat transfer core that cools and heats more rapidly than standard systems. ERV cores go a step further and assist in transferring moisture between the exhaust and fresh air, increasing comfort inside the suite. Dynamic balancing is standard on all ERV units to minimize net pressure differences between outdoor and indoor air, thus reducing drafts in the suite. Our integrated ERV solutions include multiple dampers and temperature sensors to ensure cores do not freeze when outside temperatures drop below freezing.



Product Portfolio

Nomenclature Key—Model Number

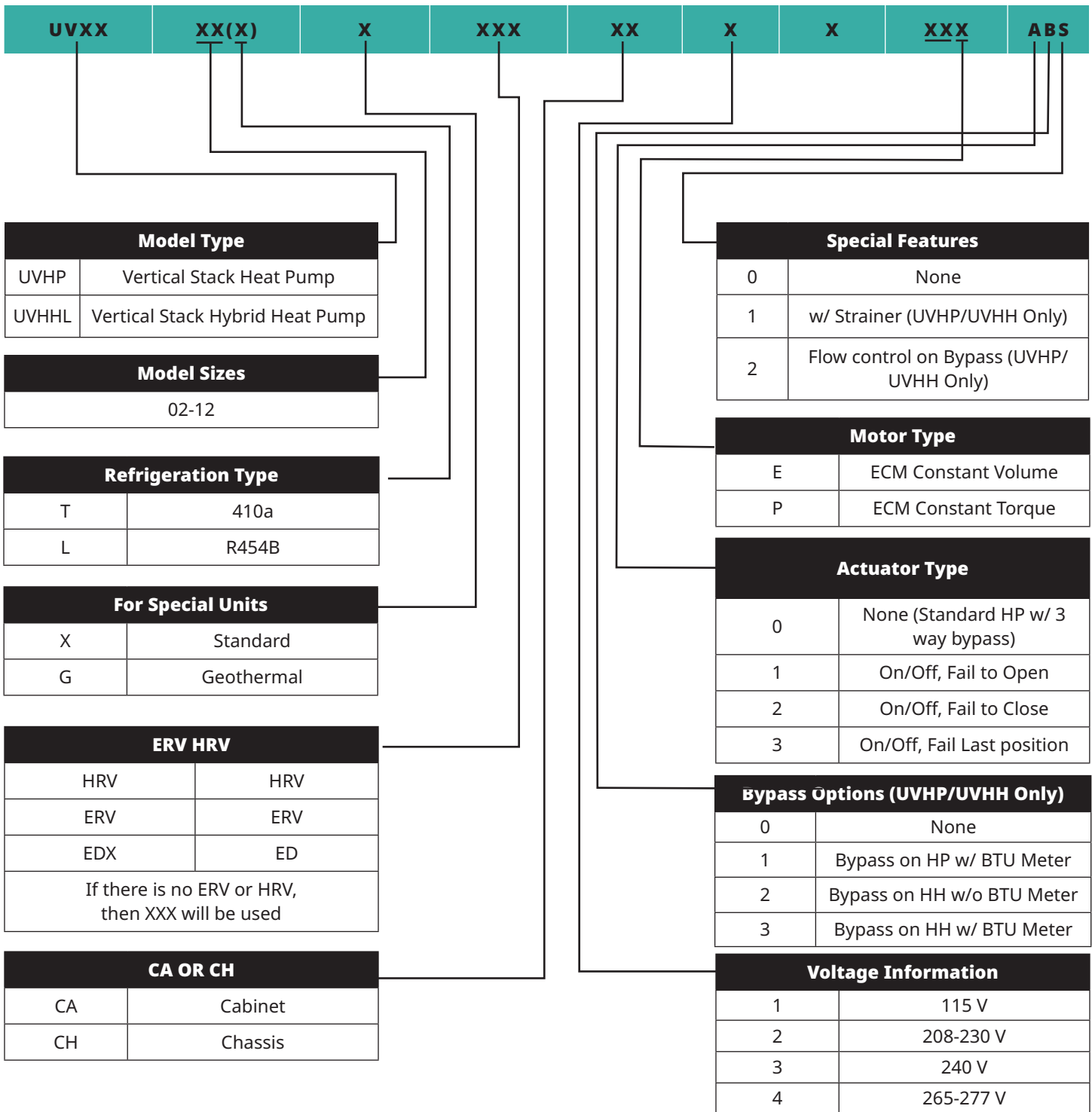

Here are some examples:

- UVHHL06L-X-ERV-CA-2-X-XXX-000
- UVHP05L-G-ERV-CA-2-X-XXX-000

Product Portfolio

Nomenclature Key—Serial Number

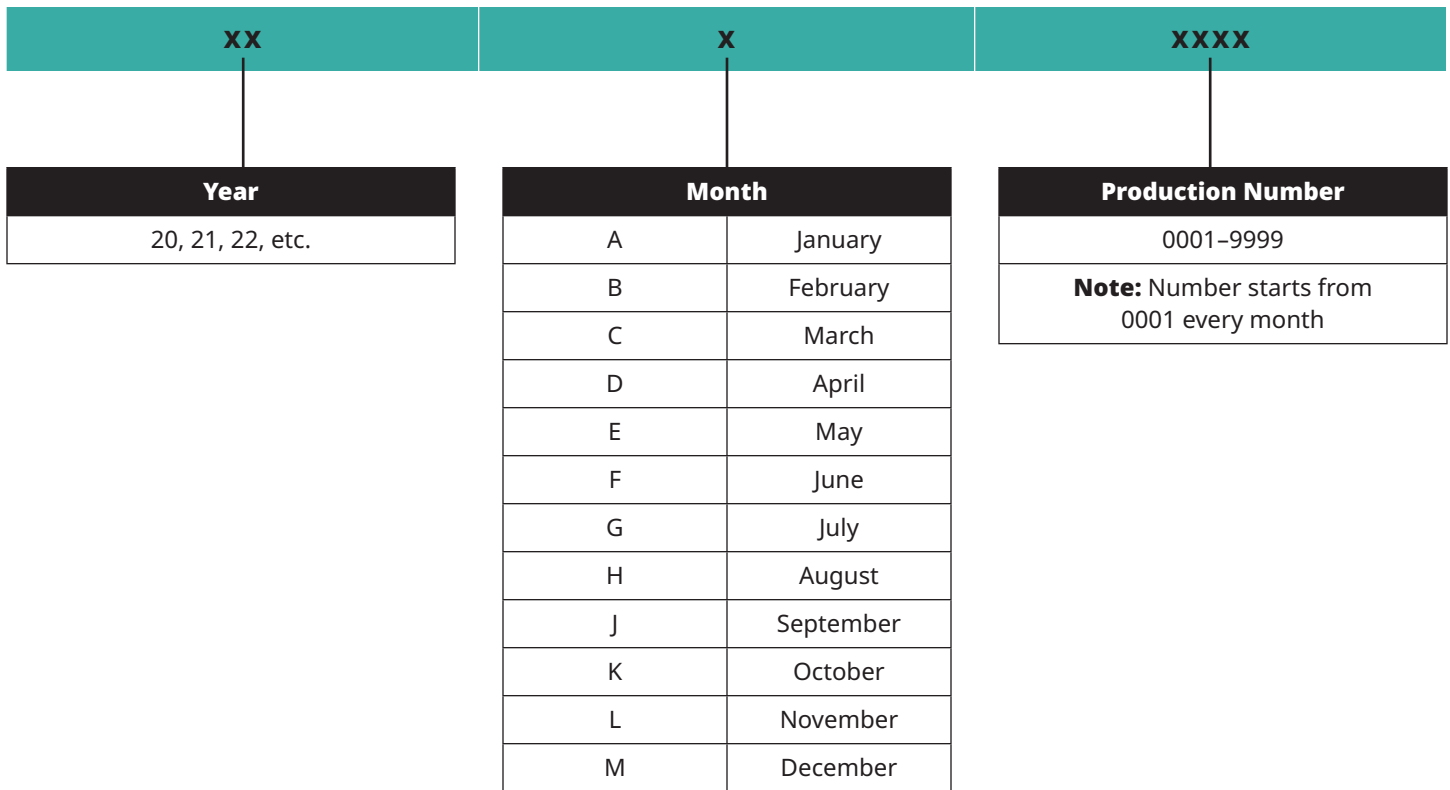

For Example:

1. 22F0001—The serial number for the 1st unit of the month on June 1, 2022
2. 20B0382—The serial number for the 382nd unit of the month during February, 2020

Features, Options, Accessories

Controls

Heat Pump Logger

Easily diagnose heat pump issues on-site with our advanced diagnostics data logger. Technicians can view real-time information about the heat pump including current alerts, compressor and valve status, fault history, and more.

Drain Pan Overflow Sensor

All heat pump units are equipped with a float switch to detect rising water levels in the drain pan and turn off the unit if in danger of overflowing.

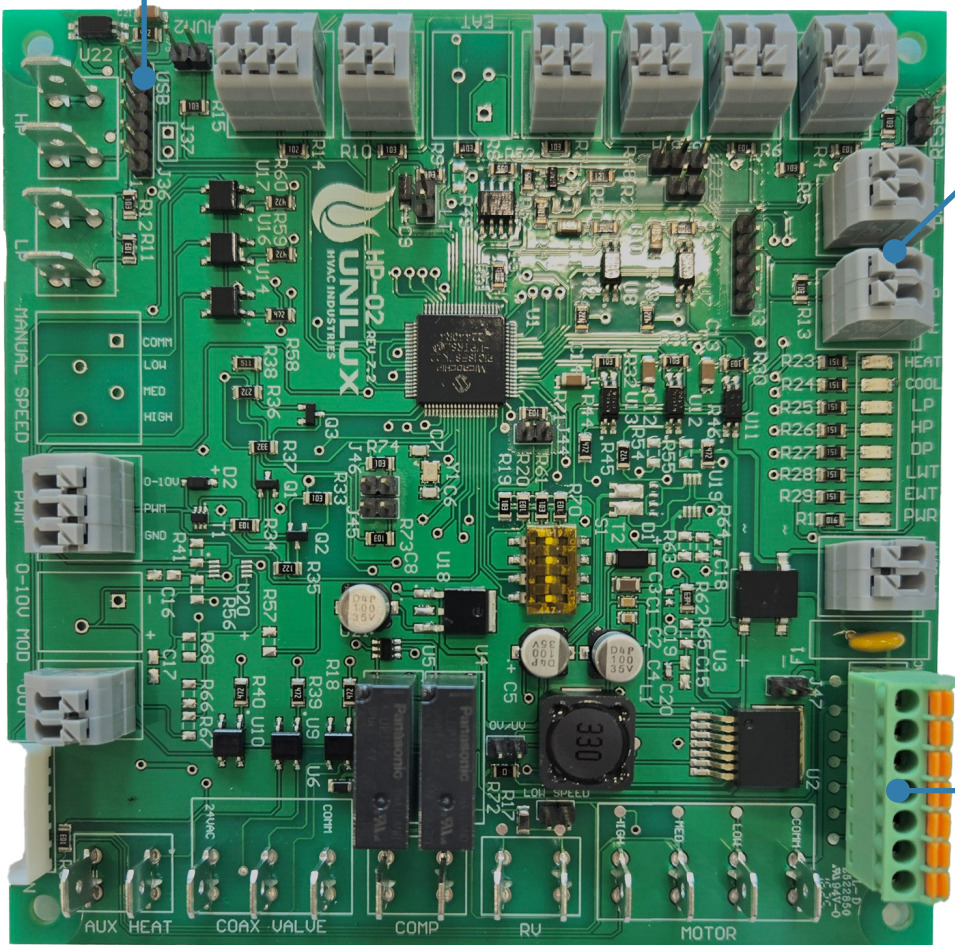

Thermostat

Our standard heat pump control boards are compatible with most thermostats. Unilux offers 7 day programmable thermostats on all heat pumps, or easily install your favorite thermostat.

20/40/60 Timer

ERV heat pumps allow for a sleek control switch to be installed in bathroom suites for exhaust ventilation. Choose between a 20, 40, and 60 minute countdown with the push of a button.



Features, Options, Accessories

Return Air Panels

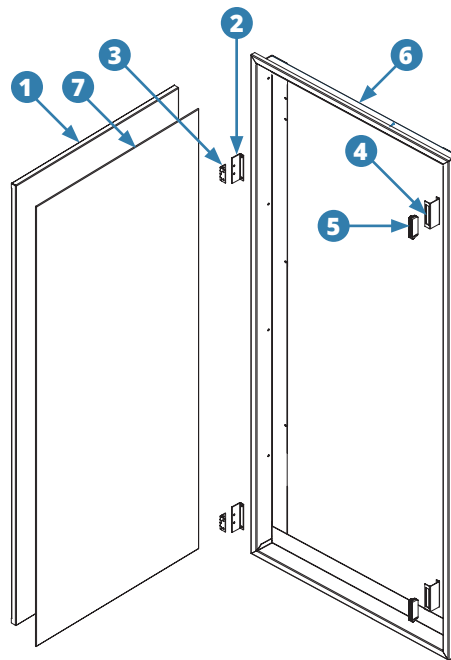

1. Return Air Panel Door
2. Hinge Bracket
3. Surface Mount Hinge
4. Magnetic Latch Bracket
5. Magnetic Latch
6. Return Air Panel Frame Assembly
7. Acoustic Sound Barrier

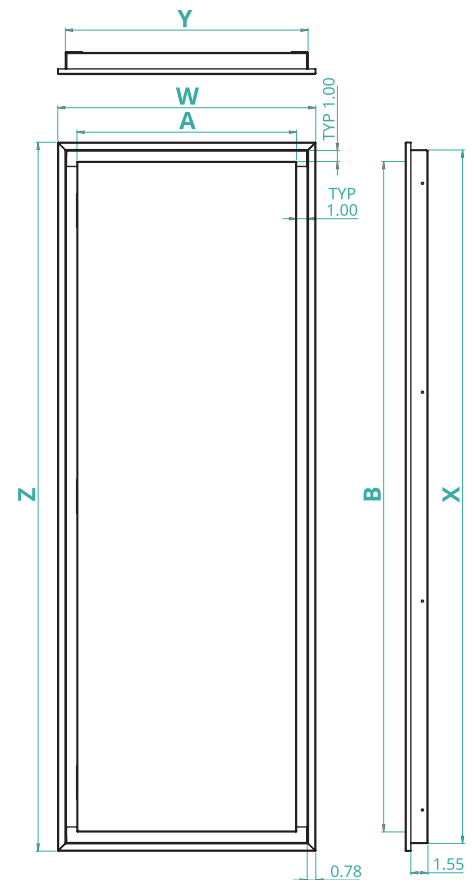

Notes:

- All hinges, brackets, and magnets are concealed behind door
- Constructed with 20-gauge steel
- Powder coat finish in Erie P7094 Unilux White
- Select colour matching available

| Access Panel Dimensions | | | | | | | | |
|--------------------------|--------------------------|--|-----|-----|-------|-------|---------|---------|
| Access Panel Part Number | Used on Unit Model | Cabinet Size Variation (see pages 19-22) | X | Y | Z | W | A | B |
| 1850-VHP-(02-04)-4000 | UVHPL/-G & UVHHL | Model-02-04 Non ERV | 50" | 18" | 51.5" | 19.5" | 15.975" | 47.975" |
| 2250-VHP-(05-12)-6000 | UVHPL/-G & UVHHL | Model-05-12 Non ERV | 50" | 22" | 51.5" | 23.5" | 19.975" | 47.975" |
| 2263-VHP-ERV-5000 | UVHPL/-G-ERV & UVHHL-ERV | Model-02-12 With ERV | 63" | 22" | 64.5" | 23.5" | 19.975" | 60.975" |

Features, Options, Accessories

Supply Air Grille

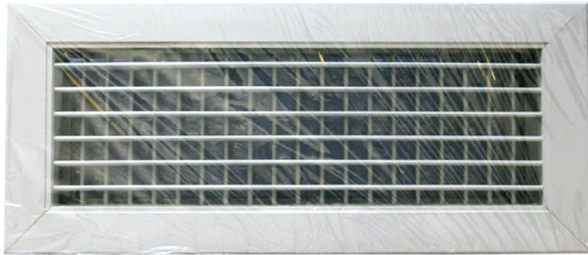

- Horizontal blades in the front with vertical blades placed behind them
- Vertical and horizontal blades are individually adjustable and have 2/3" spacing
- Aluminum roll-formed blade with semi-airfoil design
- Pressure fit nylon pivot pins (rattle-free & non-loosening)
- Aluminum extruded frame with mechanically locked corners
- Countersunk screw holes c/w painted mounting screws
- Sealing gasket prevents streaking on walls or ceiling
- Durable white powder-coat paint finish

Supply Air Register

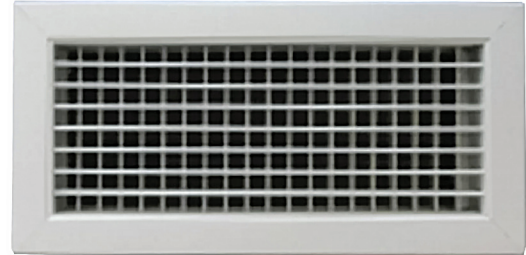

- Horizontal blades are in the front with vertical blades positioned behind them
- Horizontal and vertical blades individually adjustable and have 2/3" spacing
- Opposed Blade Damper with slide operator
- Aluminum roll-formed blade with semi-airfoil design
- Pressure fit nylon pivot pins (rattle free & non-loosening)
- Aluminum extruded frame with mechanically locked corners
- Countersunk screw holes c/w painted mounting screws
- Sealing gasket prevents streaking on walls or ceiling
- Durable white powder coat paint finish

Both models come in following sizes:

14" x 6" 14" x 8" 14" x 10"
 16" x 6" 16" x 8" 16" x 10"

Filters

One standard disposable filter and one MERV 8 air filter are provided with every heat pump.

Highlights:

- 100% synthetic pleated media
- Low resistance to air flow means minimal energy costs
- Moisture resistant and will not promote microbial growth
- Effectively remove airborne irritants
- Protects heat pump chassis
- Will not warp, crack, or distort under normal operating conditions

MERV 10-13 filters are also available.

| Filter Sizes | |
|---|----------------|
| Model | Filter Size |
| UVHP02-04L (G) / UVHH02-04L (G) | 14" x 25" x 1" |
| UVHP05-06L (G) / UVHP02-06L ERV (G) / UVHH02-04L ERV | 16" x 25" x 1" |
| UVHP08-12L (G) / UVHP08-12L ERV (G) / UVHH05-12L / UVHH05-12L ERV | 32" x 16" x 1" |



Ratings and Listings

UVHPxxL Performance Data

| UVHPL - General Performance Schedule | | | | | | | |
|--------------------------------------|--------------|--------------|----------------|---------------------------|-------|---------------------------|------|
| Model | Nominal Tons | Air Flow CFM | Fluid Flow GPM | Cooling 86°F / 30°C | | Heating 68°F / 20°C | |
| | | | | Full Load Capacity (BTUH) | EER | Full Load Capacity (BTUH) | COP |
| UVHP02L | 0.50 | 315 | 1.75 | 6,900 | 13.65 | 8600 | 5.15 |
| UVHP03L | 0.75 | 355 | 2.50 | 9,000 | 15.25 | 11,625 | 5.36 |
| UVHP04L | 1.00 | 495 | 3.00 | 12,000 | 14.90 | 14,850 | 5.25 |
| UVHP05L | 1.25 | 550 | 3.75 | 13,800 | 14.10 | 16,800 | 4.91 |
| UVHP06L | 1.50 | 625 | 5.00 | 16,850 | 13.65 | 21,700 | 4.52 |
| UVHP08L | 2.00 | 802 | 6.00 | 23,500 | 13.65 | 31,000 | 4.72 |
| UVHP10L | 2.50 | 980 | 7.50 | 29,000 | 13.65 | 32,000 | 4.52 |
| UVHP12L | 3.00 | 1150 | 8.50 | 34,500 | 13.65 | 39,800 | 4.52 |



ANSI/AHRI/ASHRAE ISO Standard 13256-1



ETL Certified

Note: Cooling capacity is based on 80.6°F (27°C) EAT-db, 66.2°F (19°C) EAT-wb and 86°F (30°C) EWT; Heating capacity is based on 68°F (20°C) EAT-db, 59.0°F (15°C) EAT-wb and 68°F (20°C) EWT. Fan performance design data is based on site conditions and may vary with actual performance. CFM may vary based on fan laws. WPD without filter, access panel, and grille. Water cooling and heating performance are without hoses, flow control, and shut-off valve. Contact us for job-specific performance data sets.

Ratings and Listings

UVHPxxL(-G) Electrical Data

| Electrical Ratings | | | | | |
|--------------------|--------------|---------|----|----|---------------------------------|
| Model | Nominal Tons | Voltage | Ph | Hz | MOP (Circuit Breaker Rating, A) |
| UVHP02L(-ERV) | 0.50 | 208/230 | 1 | 60 | 15 |
| UVHP03L(-ERV) | 0.75 | 208/230 | 1 | 60 | 15 |
| UVHP04L(-ERV) | 1.00 | 208/230 | 1 | 60 | 15 |
| UVHP05L(-ERV) | 1.25 | 208/230 | 1 | 60 | 15 |
| UVHP06L(-ERV) | 1.50 | 208/230 | 1 | 60 | 15 |
| UVHP08L(-ERV) | 2.00 | 208/230 | 1 | 60 | 20 |
| UVHP10L(-ERV) | 2.50 | 208/230 | 1 | 60 | 30 |
| UVHP12L | 3.00 | 208/230 | 1 | 60 | 35 |
| UVHP12L-ERV | 3.00 | 230 | 1 | 60 | 35 |
| UVHP12L-ERV | 3.00 | 208 | 1 | 60 | 40 |

| R-454B Charge | |
|---------------|-------------|
| Model | R-454B (Oz) |
| UVHP02L | 23 |
| UVHP03L | 27.4 |
| UVHP04L | 29.50 |
| UVHP05L | 31 |
| UVHP06L | 33 |
| UVHP08L | 43 |
| UVHP10L | 49.50 |
| UVHP12L | 47.50 |

Ratings and Listings

UVHHxxL Electrical Data

| Electrical Ratings | | | | | |
|--------------------|--------------|---------|----|----|---------------------------------|
| Model | Nominal Tons | Voltage | Ph | Hz | MOP (Circuit Breaker Rating, A) |
| UVHH02L(-ERV) | 0.50 | 208/230 | 1 | 60 | 15 |
| UVHH03L(-ERV) | 0.75 | 208/230 | 1 | 60 | 15 |
| UVHH04L(-ERV) | 1.00 | 208/230 | 1 | 60 | 15 |
| UVHH05L(-ERV) | 1.25 | 208/230 | 1 | 60 | 15 |
| UVHH06L(-ERV) | 1.50 | 208/230 | 1 | 60 | 15 |
| UVHH08L(-ERV) | 2.00 | 208/230 | 1 | 60 | 20 |
| UVHH10L(-ERV) | 2.50 | 208/230 | 1 | 60 | 30 |
| UVHH12L | 3.00 | 208/230 | 1 | 60 | 35 |
| UVHH12L-ERV | 3.00 | 230 | 1 | 60 | 35 |
| UVHH12L-ERV | 3.00 | 208 | 1 | 60 | 40 |

| R-454B Charge | |
|---------------|-------------|
| Model | R-454B (Oz) |
| UVHH02L | 14.75 |
| UVHH03L | 17.25 |
| UVHH04L | 17.75 |
| UVHH05L | 22 |
| UVHH06L | 28.25 |
| UVHH08L | 28.75 |
| UVHH10L | 37 |
| UVHH12L | 34 |

Ratings and Listings

ERV Performance Schedule with Dynamic Balancing

| ERV Performance | | | |
|-----------------|-----------------------|---------------------|-----------------------|
| | Summer | | Winter |
| CFM | Sensible Eff. Cooling | Latent Eff. Cooling | Sensible Eff. Heating |
| 25 | 87.25 | 44.53 | 87.13 |
| 50 | 81.20 | 41.70 | 80.90 |
| 75 | 75.68 | 38.95 | 75.13 |
| 100 | 70.50 | 36.20 | 69.80 |

Unilux HVAC Patented Integrated HRV/ERV

U.S. Patent No. 8939826 / CDN Patent No. 2746405

Unilux HVAC Patented Dynamic Balancing

U.S. Patent Pending Application No. US20200124311 / CDN Patent No. 3059735

Ratings and Listings

Sound Pressure Level

UVHPL / UVHHL

| Unit Size | Air Flow (CFM) | Fan Speed | Octave Band / Center Frequency (Hz) | | | | | | | | Noise Criterion (NC) |
|-----------|----------------|-----------|-------------------------------------|-----|-----|-----|------|------|------|------|----------------------|
| | | | 1 | 2 | 3 | 4 | 5 | 6 | 7 | 8 | |
| | | | 63 | 125 | 250 | 500 | 1000 | 2000 | 4000 | 8000 | |
| 02 | 250 | H | 58 | 50 | 45 | 40 | 34 | 27 | 27 | 26 | 35 |
| | 215 | M | 57 | 47 | 43 | 39 | 29 | 22 | 22 | 24 | 34 |
| | 170 | L | 55 | 45 | 40 | 36 | 27 | 21 | 21 | 24 | 31 |
| 03 | 340 | H | 60 | 51 | 45 | 40 | 35 | 27 | 28 | 26 | 35 |
| | 293 | M | 59 | 47 | 42 | 38 | 29 | 21 | 22 | 24 | 33 |
| | 232 | L | 58 | 46 | 40 | 38 | 27 | 20 | 21 | 24 | 33 |
| 04 | 450 | H | 60 | 52 | 45 | 40 | 34 | 27 | 27 | 26 | 35 |
| | 387 | M | 60 | 48 | 41 | 39 | 29 | 22 | 22 | 26 | 35 |
| | 307 | L | 58 | 46 | 41 | 37 | 27 | 21 | 21 | 25 | 32 |
| 05 | 540 | H | 60 | 52 | 45 | 40 | 35 | 27 | 26 | 23 | 35 |
| | 466 | M | 60 | 49 | 42 | 38 | 31 | 22 | 22 | 23 | 35 |
| | 368 | L | 59 | 47 | 40 | 35 | 27 | 22 | 21 | 22 | 33 |
| 06 | 650 | H | 61 | 52 | 46 | 41 | 35 | 28 | 25 | 20 | 36 |
| | 483 | M | 60 | 51 | 43 | 40 | 31 | 26 | 20 | 19 | 35 |
| | 382 | L | 59 | 49 | 42 | 37 | 28 | 22 | 18 | 18 | 33 |
| 08 | 810 | H | 61 | 52 | 46 | 42 | 37 | 31 | 27 | 24 | 37 |
| | 700 | M | 59 | 50 | 45 | 40 | 35 | 29 | 25 | 22 | 35 |
| | 553 | L | 57 | 46 | 42 | 37 | 34 | 27 | 21 | 21 | 33 |
| 10 | 1000 | H | 61 | 53 | 47 | 42 | 37 | 33 | 26 | 24 | 37 |
| | 863 | M | 59 | 51 | 46 | 40 | 35 | 32 | 24 | 22 | 35 |
| | 683 | L | 58 | 48 | 44 | 38 | 34 | 30 | 20 | 20 | 33 |
| 12 | 1200 | H | 62 | 53 | 48 | 43 | 37 | 33 | 27 | 23 | 38 |
| | 1035 | M | 59 | 50 | 46 | 40 | 36 | 31 | 24 | 20 | 35 |
| | 820 | L | 58 | 47 | 44 | 38 | 35 | 29 | 20 | 19 | 34 |

Note: Above design sound pressure data may vary with actual. Performance is based on multi-speed ECM motors, with a standard front Return Air Grille and 1 inch pleated MERV 8 filter. Unit was tested in 16,421 ft³ (465 m³) reverberation room, with measurement taken at a distance of 4.9 ft (1.5 m), close to two adjacent flat surfaces perpendicular to each other; able to radiate to one fourth of a sphere.

Ratings and Listings

Sound Power Level

UVHPL / UVHHL

| Unit Size | Air Flow (CFM) | Fan Speed | Octave Band / Center Frequency (Hz) | | | | | | | | Noise Criterion (NC) |
|-----------|----------------|-----------|-------------------------------------|-----|-----|-----|------|------|------|------|----------------------|
| | | | 1 | 2 | 3 | 4 | 5 | 6 | 7 | 8 | |
| | | | 63 | 125 | 250 | 500 | 1000 | 2000 | 4000 | 8000 | |
| 02 | 250 | H | 58 | 50 | 45 | 40 | 34 | 27 | 27 | 26 | 35 |
| | 215 | M | 57 | 47 | 43 | 39 | 29 | 22 | 22 | 24 | 34 |
| | 170 | L | 55 | 45 | 40 | 36 | 27 | 21 | 21 | 24 | 31 |
| 03 | 340 | H | 60 | 51 | 45 | 40 | 35 | 27 | 28 | 26 | 35 |
| | 293 | M | 59 | 47 | 42 | 38 | 29 | 21 | 22 | 24 | 33 |
| | 232 | L | 58 | 46 | 40 | 38 | 27 | 20 | 21 | 24 | 33 |
| 04 | 450 | H | 60 | 52 | 45 | 40 | 34 | 27 | 27 | 26 | 35 |
| | 387 | M | 60 | 48 | 41 | 39 | 29 | 22 | 22 | 26 | 35 |
| | 307 | L | 58 | 46 | 41 | 37 | 27 | 21 | 21 | 25 | 32 |
| 05 | 540 | H | 60 | 52 | 45 | 40 | 35 | 27 | 26 | 23 | 35 |
| | 466 | M | 60 | 49 | 42 | 38 | 31 | 22 | 22 | 23 | 35 |
| | 368 | L | 59 | 47 | 40 | 35 | 27 | 22 | 21 | 22 | 33 |
| 06 | 650 | H | 61 | 52 | 46 | 41 | 35 | 28 | 25 | 20 | 36 |
| | 483 | M | 60 | 51 | 43 | 40 | 31 | 26 | 20 | 19 | 35 |
| | 382 | L | 59 | 49 | 42 | 37 | 28 | 22 | 18 | 18 | 33 |
| 08 | 810 | H | 61 | 52 | 46 | 42 | 37 | 31 | 27 | 24 | 37 |
| | 700 | M | 59 | 50 | 45 | 40 | 35 | 29 | 25 | 22 | 35 |
| | 553 | L | 57 | 46 | 42 | 37 | 34 | 27 | 21 | 21 | 33 |
| 10 | 1000 | H | 61 | 53 | 47 | 42 | 37 | 33 | 26 | 24 | 37 |
| | 863 | M | 59 | 51 | 46 | 40 | 35 | 32 | 24 | 22 | 35 |
| | 683 | L | 58 | 48 | 44 | 38 | 34 | 30 | 20 | 20 | 33 |
| 12 | 1200 | H | 62 | 53 | 48 | 43 | 37 | 33 | 27 | 23 | 38 |
| | 1035 | M | 59 | 50 | 46 | 40 | 36 | 31 | 24 | 20 | 35 |
| | 820 | L | 58 | 47 | 44 | 38 | 35 | 29 | 20 | 19 | 34 |

Note: Above design sound power data may vary with actual. Performance is based on multi-speed ECM motors, with a standard front Return Air Grille and 1 inch pleated MERV 8 filter. Unit was tested in 16,421 ft³ (465 m³) reverberation room, with measurement taken at a distance of 4.9 ft (1.5 m), close to two adjacent flat surfaces perpendicular to each other; able to radiate to one fourth of a sphere.

Ratings and Listings

Fan Curves

UVHPL & UVHHL

UVHP02L/UVHH02L

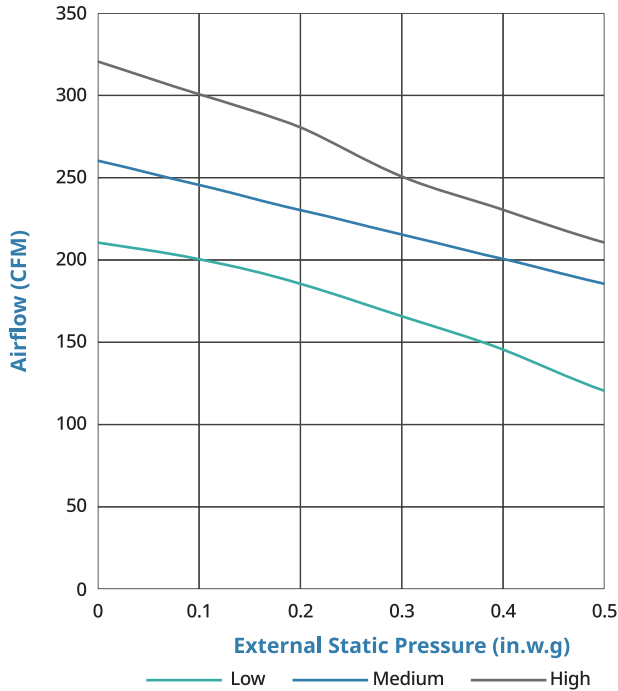

UVHP03L/UVHH03L

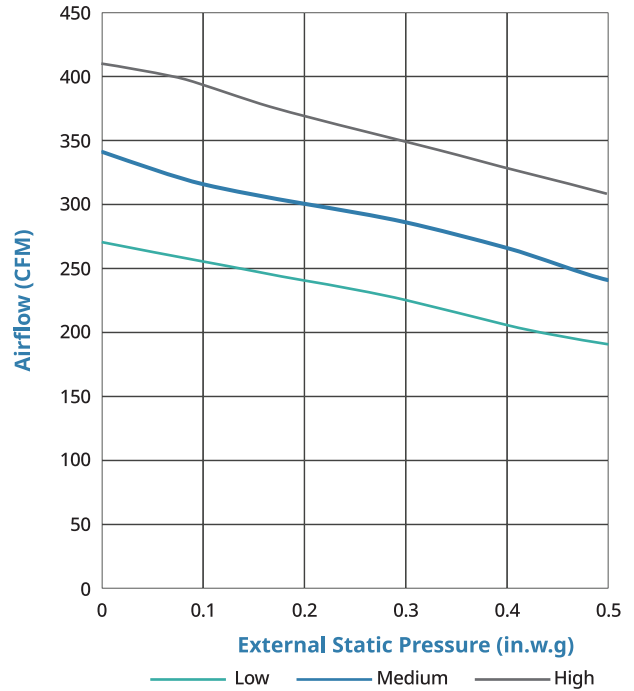

UVHP04L/UVHH04L

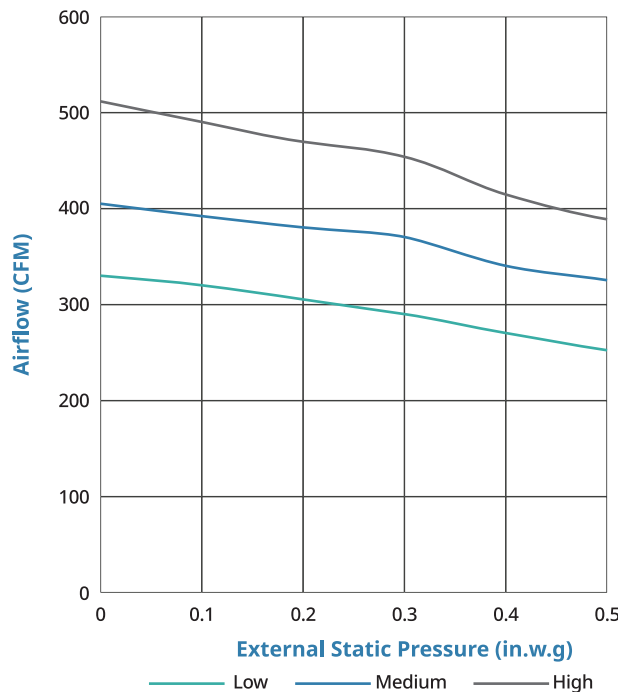

UVHP05L/UVHH05L

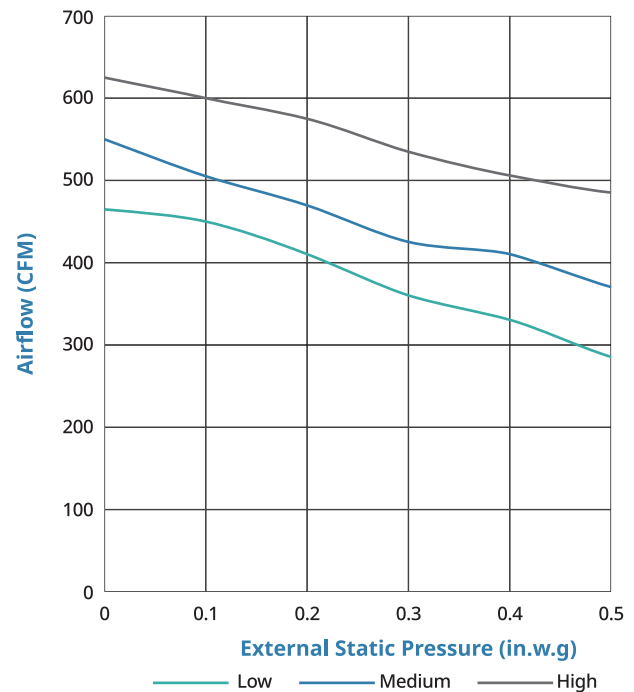

Performance Data

Fan Curves

UVHPL & UVHHL cont...

UVHP06L/UVHH06L

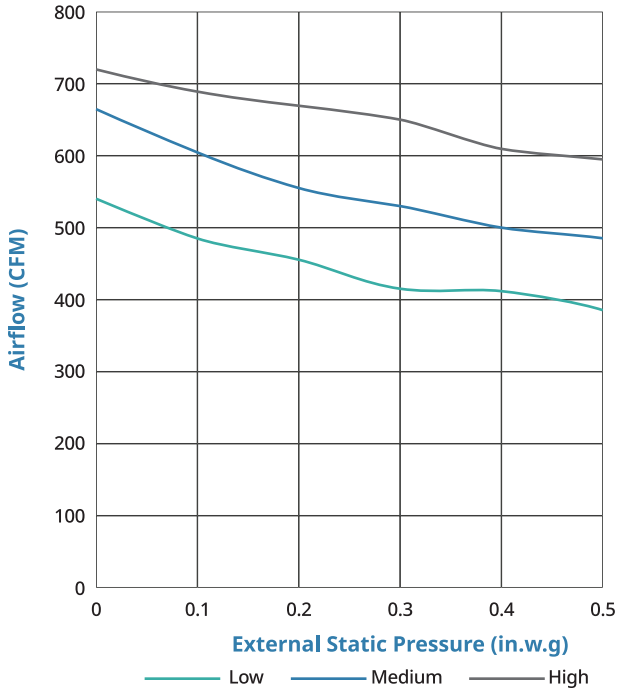

UVHP08L/UVHH08L

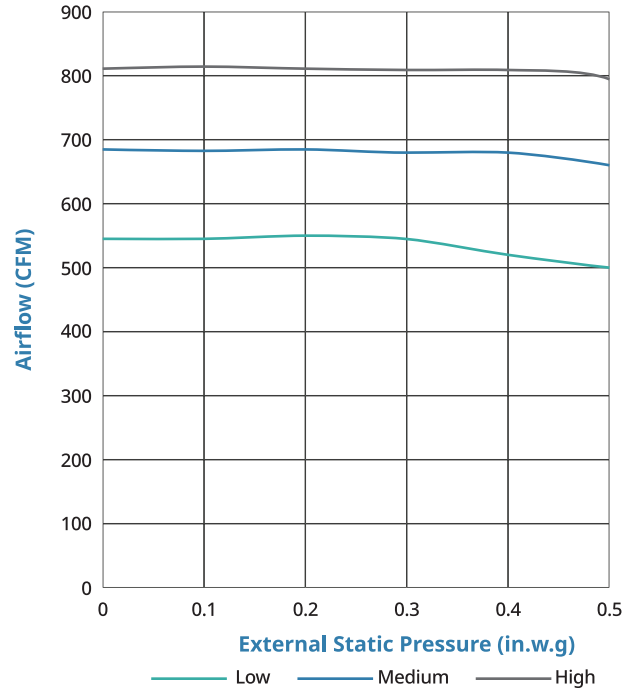

UVHP10L/UVHH10L

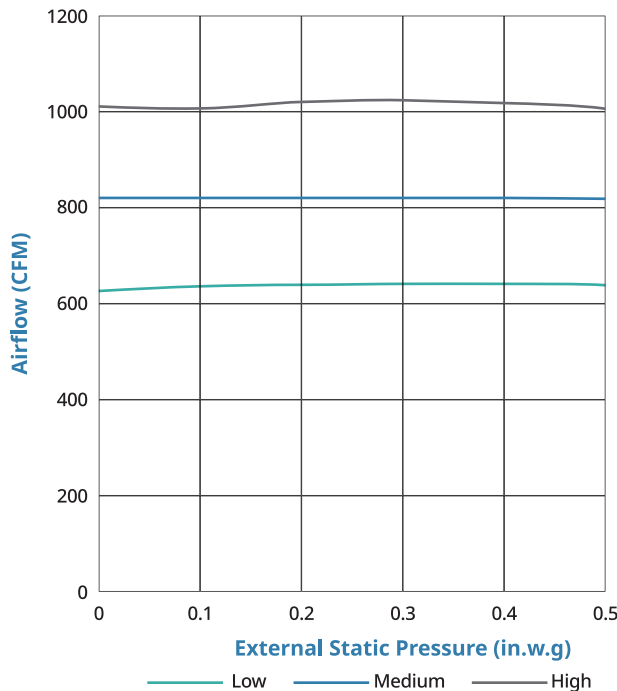

UVHP12L/UVHH12L

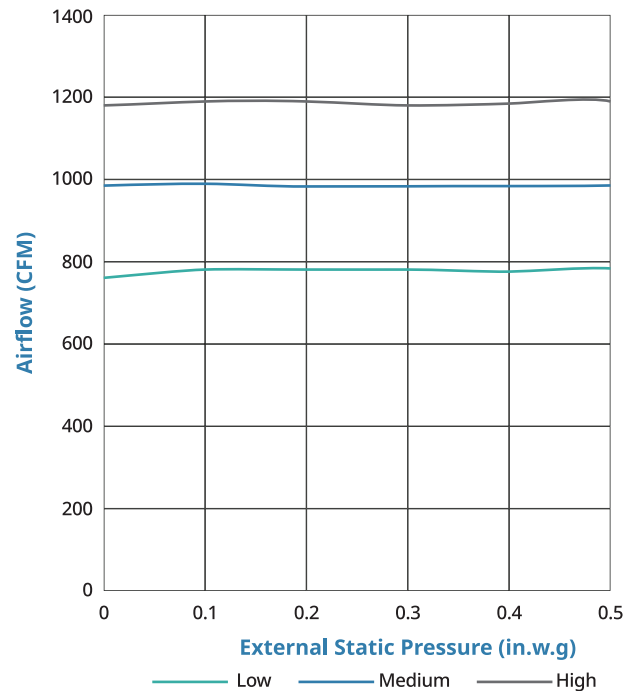

Ratings and Listings

Copper Riser Sizing, Insulation, and Expansion

Unilux HVAC uses industry standard copper risers for all heat pump units. Type L copper supply/return risers are available in ¾"-4" diameters and DWV condensate risers are available in 1 ¼" diameter. Vertical stack heat pump risers are typically factory installed. Fiberglass insulation can be provided to meet your specification.

Each riser size and length is determined by the position of the heat pump in the building. Riser sizing is based on the water flow requirements of each unit in the riser stack, and the heat pump system being used. Riser stacks must begin with the largest diameter at the bottom and progressively decrease as the water flows to the top of the stack. Risers should limit the velocity to 4-7 feet per second. The chart to the right can be used as a quick reference for riser sizing, but does not take the place of an engineered piping design.

As copper expands and contracts with temperature changes, compensation must be built into the piping system. The expansion of a riser column can be calculated as:

$$\begin{aligned}
 &\text{Temperature Rise (°F)} \\
 &\times \text{Length (feet)} \\
 &\times 12 \text{ (inches per foot)} \\
 &\times 0.000094 \text{ (Average Expansion Coefficient)} \\
 &= \text{Expansion (inches)}
 \end{aligned}$$

The table to the right shows the expected expansion/contraction per 100 feet. All risers allow for ±1.5 inches of movement due to expansion and contraction. Any additional compensation is the responsibility of the contractor.

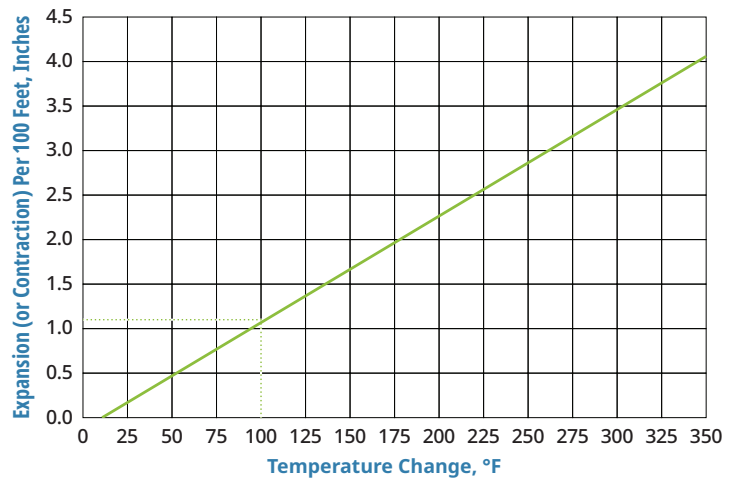
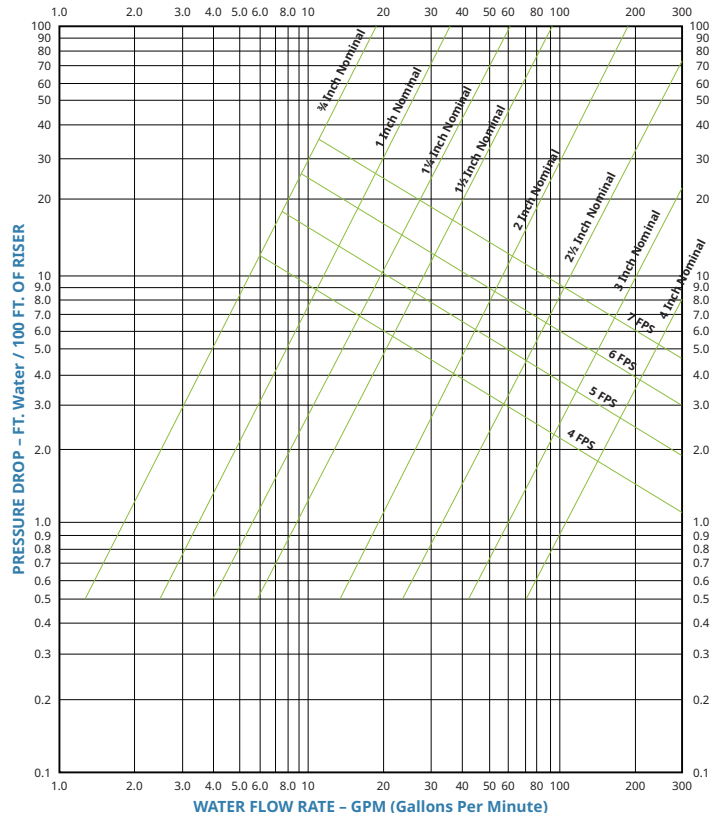

Submittal Data

Cabinet Dimensions

Standard Cabinets—UVHPL(G)/UVHHL

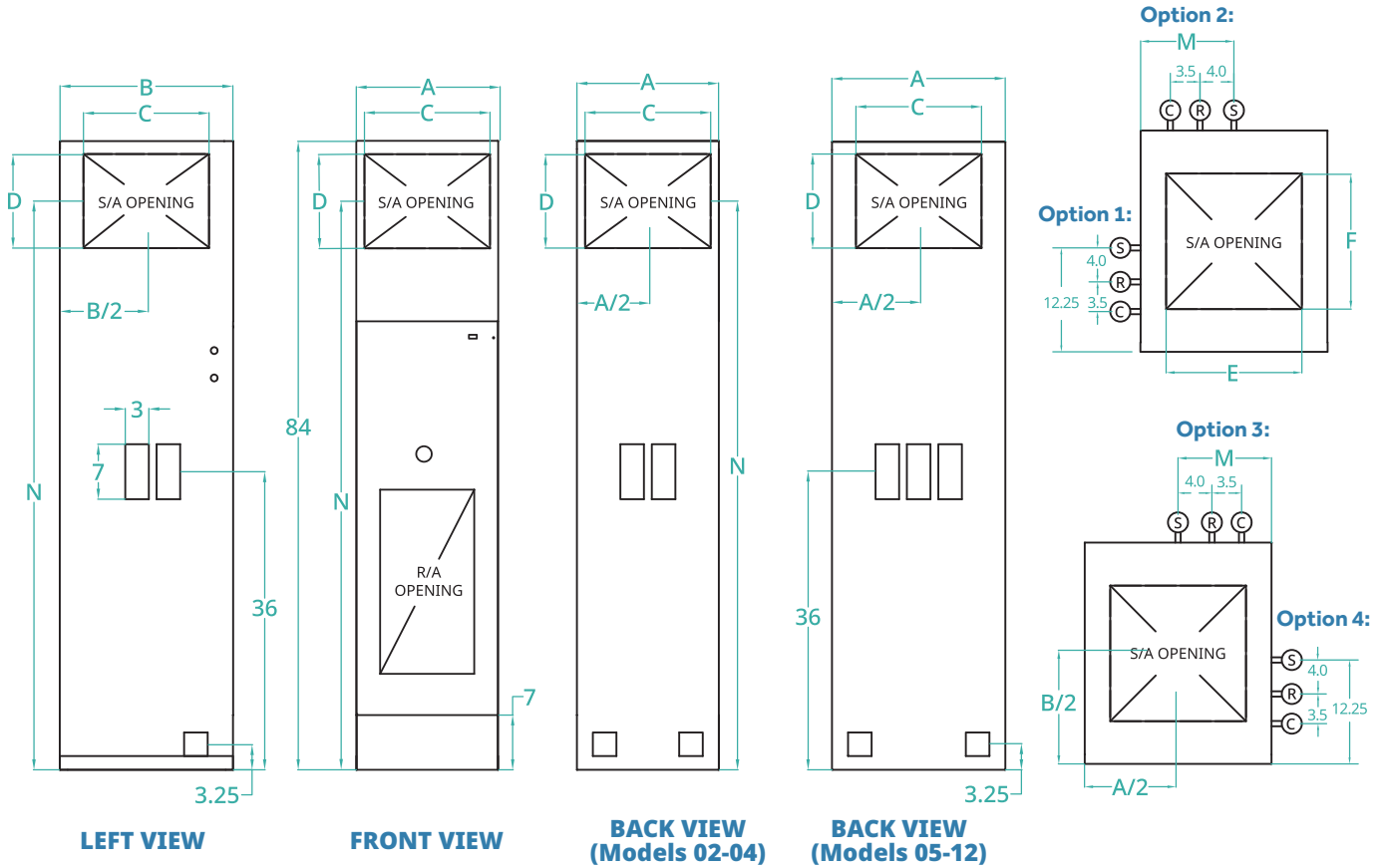

| | SMALL CABINET | | | MEDIUM CABINET | | | LARGE CABINET | |
|----------------|---------------------|---------------------|---------------------|---------------------|---------------------|---------------------|---------------------|---------------------|
| | UVHP02L/ UVHH02L | UVHP03L/ UVHH03L | UVHP04L/ UVHH04L | UVHP05L/ UVHH05L | UVHP06L/ UVHH06L | UVHP08L/ UVHH08L | UVHP10L/ UVHH10L | UVHP12L/ UVHH12L |
| TONNAGE | 0.50 T | 0.75 T | 1.00 T | 1.25 T | 1.50 T | 2.00 T | 2.50 T | 3.00 T |
| A | 16" | | | 20" | | | 20" | |
| B | 17.5" | | | 19.25" | | | 23" | |
| C x D | 14 x 8 | | | | | 16 x 8 | | |
| E x F | 14 x 6 / 14 x 8 | | | | | 14 x 6 / 16 x 10 | | |
| M | 10" | | | | | | | |
| N | 78" | | | | | | | |

Submittal Data

ERV Cabinets—UVHPL(G)/UVHHL

- EI:** Exhaust Air Intake from Bathroom (5" Diameter)
- EO:** Exhaust Air to Outside (6.5" × 4")
- FI:** Fresh Air Intake from Outside (5" Diameter)

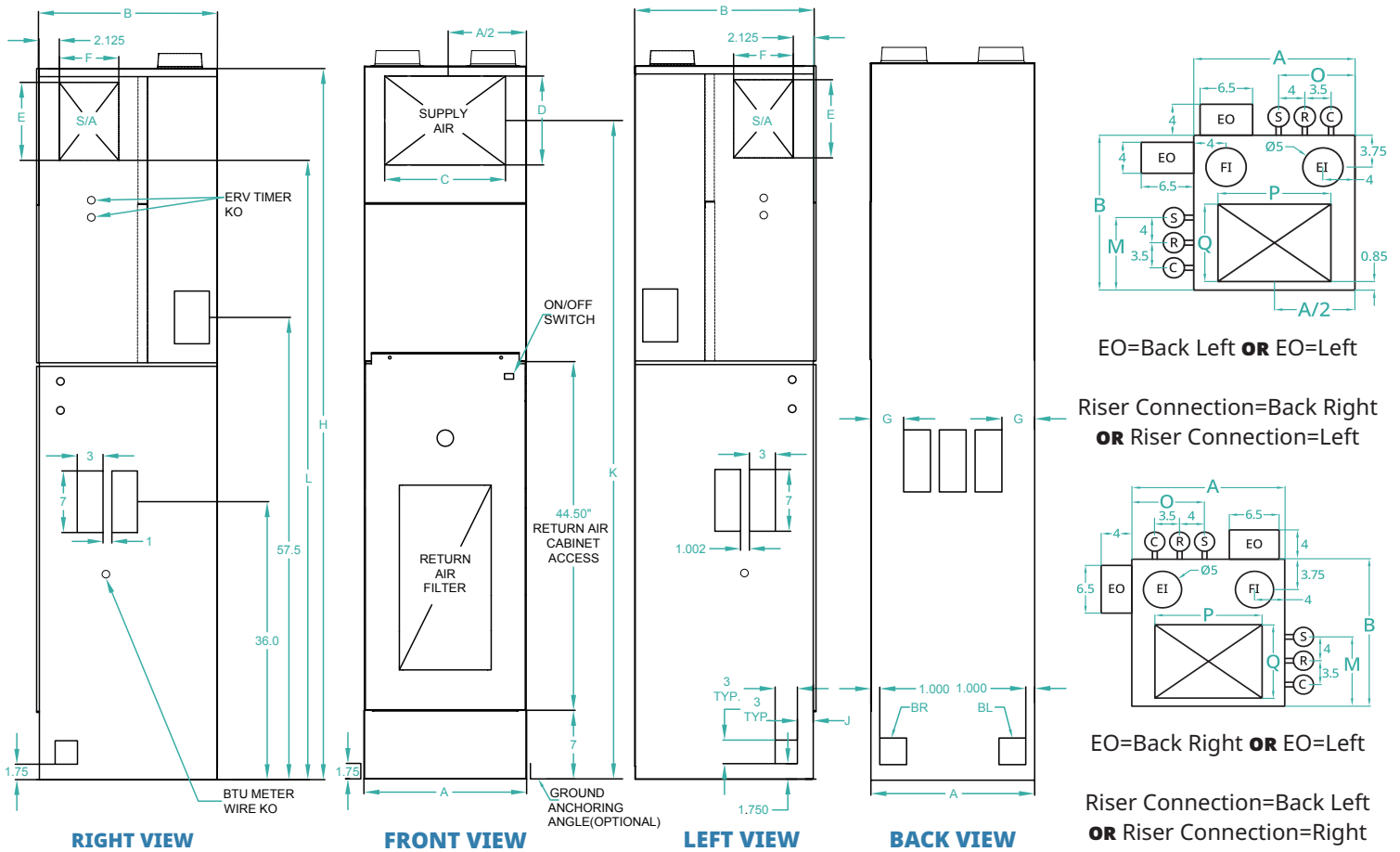

| | MEDIUM CABINET | | | | | | LARGE CABINET | |
|----------------|-----------------------------|-----------------------------|-----------------------------|-----------------------------|-----------------------------|-----------------------------|-----------------------------|-----------------------------|
| | UVHP02L-ERV/ UVHH02L-ERV | UVHP03L-ERV/ UVHH03L-ERV | UVHP04L-ERV/ UVHH04L-ERV | UVHP05L-ERV/ UVHH05L-ERV | UVHP06L-ERV/ UVHH06L-ERV | UVHP08L-ERV/ UVHH08L-ERV | UVHP10L-ERV/ UVHH10L-ERV | UVHP12L-ERV/ UVHH12L-ERV |
| TONNAGE | 0.50 T | 0.75T | 1.00 T | 1.25 T | 1.50 T | 2.00 T | 2.50 T | 3.00 T |
| A | 20" | | | | | | | |
| B | 19.25" | | | | | | 23" | |
| C | 14 | | | | 16 | | | |
| D | 8 | | | | | | | |
| E x F | 10 x 6 / 16 x 8 | | | | | | 10 x 6 / 14 x 10 / 16 x 10 | |
| K | 78" | | | | | | | |
| L | 68.5-72.5" | | | | | | | |
| M | 12.25" | | | | | | | |
| O | 10" | | | | | | | |
| P | 14" | | | | | | | |
| Q | 10" | | | | | | 12" | |
| H | 84" | | | | | | | |

Submittal Data

UVHP/UVHH-XX-ED

EI: Exhaust Air Intake from Bathroom (5" Diameter)
EO: Exhaust Air to Outside (6.5" x 4")
FI: Fresh Air Intake from Outside (5" Diameter)

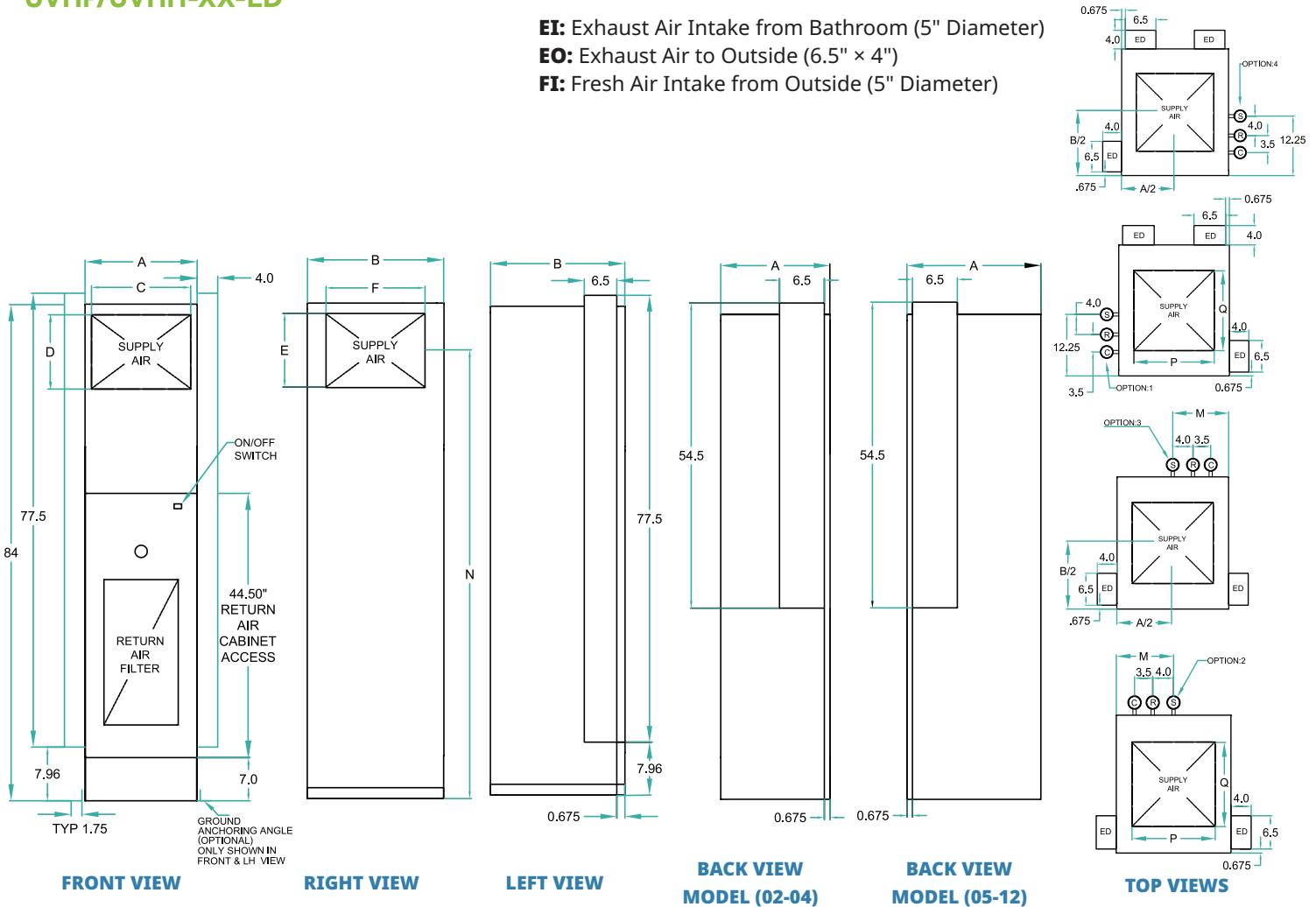

| | MEDIUM CABINET | | | | | | LARGE CABINET | |
|----------------|------------------------|------------------------|------------------------|------------------------|------------------------|------------------------|------------------------|------------------------|
| | UVHP02-ED UVHH02-ED | UVHP03-ED UVHH03-ED | UVHP04-ED UVHH04-ED | UVHP05-ED UVHH05-ED | UVHP06-ED UVHH06-ED | UVHP08-ED UVHH08-ED | UVHP10-ED UVHH10-ED | UVHP12-ED UVHH12-ED |
| TONNAGE | 0.50 T | 0.75T | 1.00 T | 1.25 T | 1.50 T | 2.00 T | 2.50 T | 3.00 T |
| A | 16 | | | 20 | | | 20 | |
| B | 17.50 | | | 19.25 | | | 23" | |
| C x D | 14 x 8 | | | | | 16 x 8 | | |
| E x F | 14 x 6 / 14 x 8 | | | | | | 14 x 6 / 16 x 10 | |
| K | 78" | | | | | | | |
| L | 68.5-72.5" | | | | | | | |
| M | 10 | | | | | | | |
| O | 78 | | | | | | | |
| P | 14" | | | | | | | |
| Q | 12 | | | | | | 14 | |
| H | 12 | | | | | | 14 | |

Submittal Data

Airflow and Riser Configurations

UVHPL(G)/UVHHL/UVHPL Configurations

Single Side Supply Air

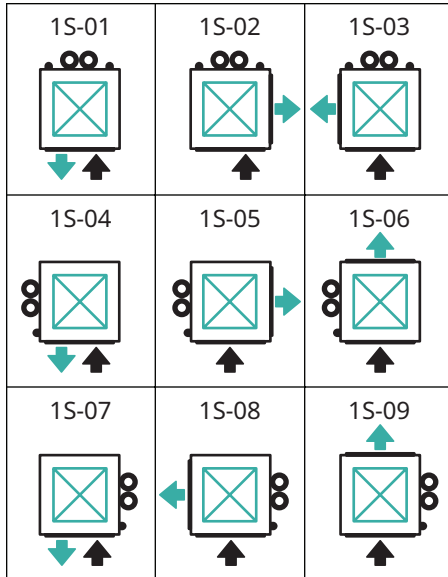

Top Plus One Side Supply Air

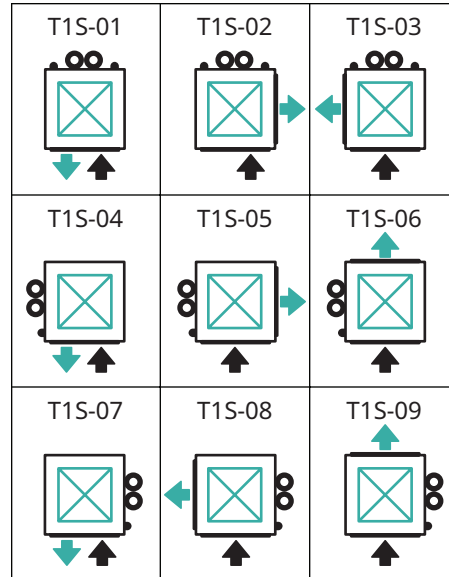

Three Side Supply Air

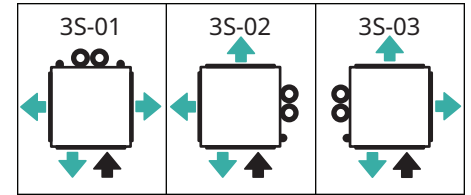

Top Plus Three Side Supply Air

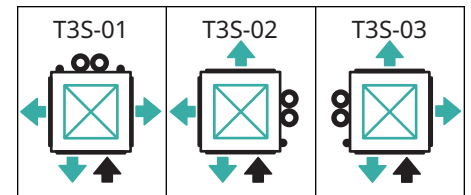

Top Only Supply Air

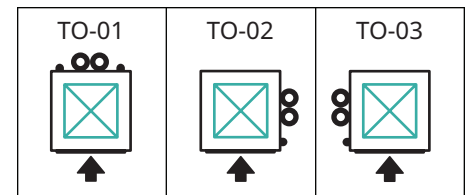

Double-Sided Supply Air

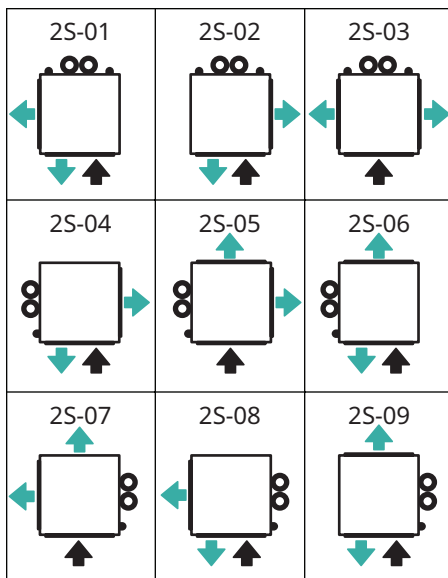

Top Plus Two Side Supply Air

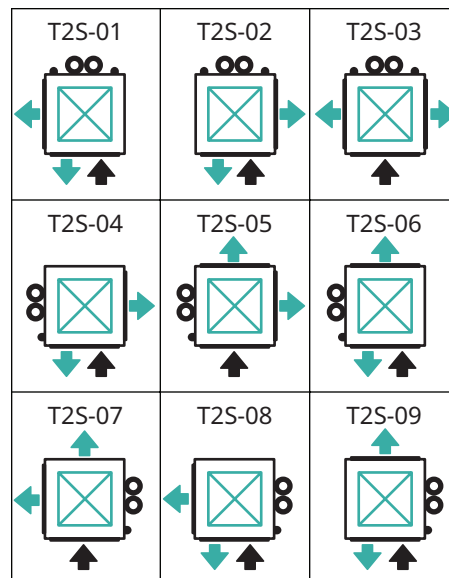

Special Note: When located at the back of the heat pump unit, the drain can be either a Back Left (BL) connection or a Back Right (BR) Connection, but not both at the same time.

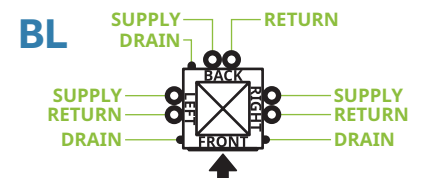
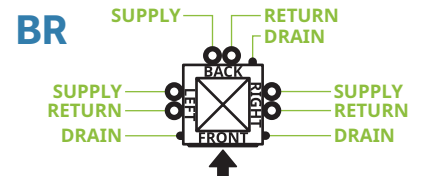

Submittal Data

UVHPL / UVHHL / UVHPL-G with ERV Configurations

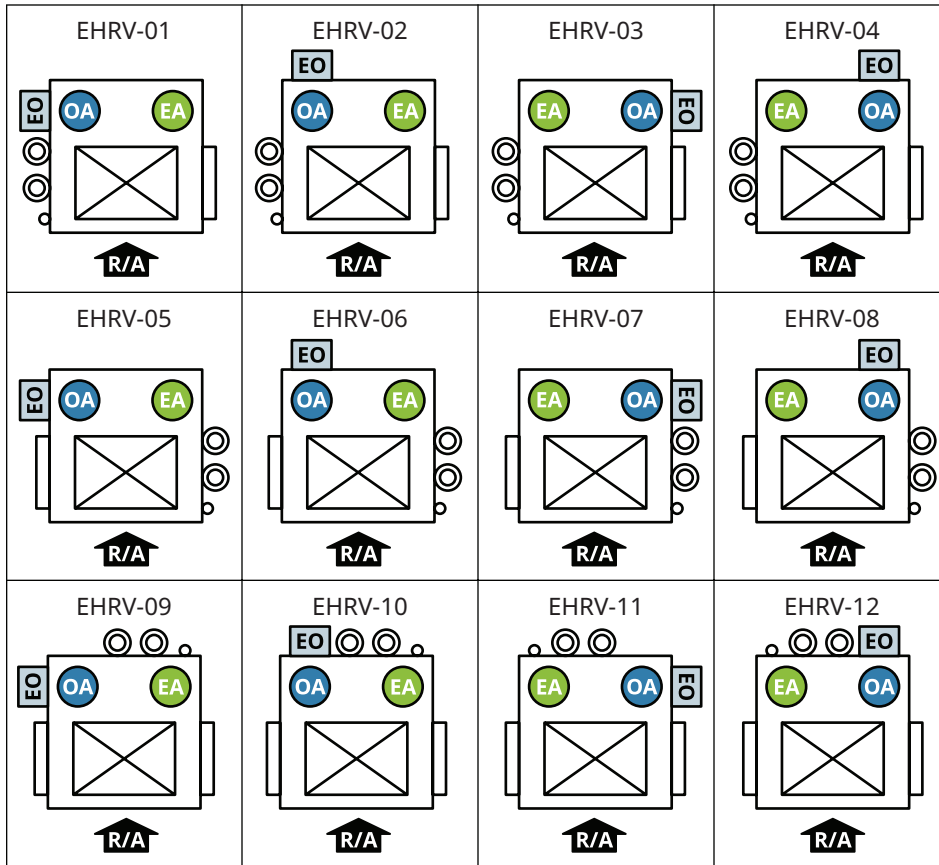

OA = Fresh Air Intake from Outside

EA = Exhaust Air Intake from Bathroom

EO = ERV/HRV Exhaust Air to Outside

R/A = Return Air

Note: ERV or HRV exhaust duct (EO) is always beside Fresh Air Intake (OA).

If Fresh Air Intake (OA) is on left-hand side of unit (Stand in front of R/A to determine Left or Right side of unit), then EO can be Back Left (BL) or Left (L). If EO and risers are not the same side, EO can be BL, risers are Back Right (BR)

Part 2:
**Installation, Operation,
and Maintenance**

General Safety Guidelines

Important—Read Before Proceeding

During installation, operation, maintenance, or service, individuals may be exposed to certain components or conditions including, but not limited to refrigerants, oils, materials under pressure, rotating components, and both high and low voltage. Each of these items has the potential if misused, or handled improperly, to cause bodily harm, injury, or death. It is the obligation and responsibility of operating/service personnel to identify and recognize these inherent hazards, protect themselves, and proceed safely in completing their tasks. Failure to comply with any of these requirements could result in serious damage to the equipment and the property in which it is situated, as well as severe personal injury or death.

This document is intended for use by the owner and authorized operating/service personnel. It is expected that this individual possesses independent training that will enable them to perform their assigned tasks properly and safely. It is essential that, before performing any task on this equipment, this individual shall have read and understood this document and any referenced materials.

All wiring must be in accordance with the national wiring regulations or local wiring regulations, whichever takes jurisdiction in the region, and must be performed **ONLY** by qualified service personnel. Unilux HVAC will not be responsible for damages/problems resulting from improper connections to controls or application of improper control signals. Failure to follow this will void the manufacturer’s warranty and may cause serious damage to property or injury to persons.

This appliance is not intended for use by persons (including children) with reduced physical, sensory, or mental capabilities, or lack of experience and knowledge, unless they have been given supervision or instruction concerning use of the appliance by a person responsible for their safety. Children should be supervised to ensure they do not play with the appliance.

Symbols, Warnings, and Notices



Warning: Indicates flammable refrigerant.



Warning: Indicates a potentially dangerous situation that could result in death or serious injury.



Caution: Indicates a possibly hazardous situation which could result in possible injuries or damage to the unit and/or environmental pollution, or to alert against unsafe practices.



Note: Identifies important information to the technician to complete the task correctly.

Responsible Refrigerant Practices

All technicians who handle flammable A2L refrigerants must be certified in accordance with local codes for reclaiming, recovering, recycling, and handling of refrigerants. Technicians must follow all applicable local and federal laws.



Correct field wiring and grounding are required, failure to adhere and follow code could result in the death or serious injury. **All field wiring must be performed only by a qualified electrician.** All wiring must be in accordance with the manufacturer’s specifications.



Wiring that is improperly installed and/or grounded could result in **fire, electrocution,** and other serious hazards. The manufacturer is not responsible for damaged equipment or site issues resulting from the improper connections of the unit or the use of improper controls.



Do not use means to accelerate the defrosting process or to clean, other than those recommended by the manufacturer. The appliance shall be stored in a room without continuously operating ignition sources (i.e. open flames, an operating gas appliance or an operating electric heater). Do not pierce or burn. Be aware that refrigerants may not contain an odour. Ensure to keep any required ventilation openings clear of obstruction. The ducts connected to the unit shall not contain Potential Ignition Surface.



Personal Protective Equipment (PPE) is mandatory. Technicians installing or servicing this unit must use all PPE including but not limited to hard hats, safety glasses, cut resistant sleeves and gloves, electrical PPE, and fall protection.

General Safety Guidelines

Transportation, Marking, and Storage for Units that Employ Flammable Refrigerants

The following information is provided for units that employ flammable refrigerants.

Transport of Equipment Containing Flammable Refrigerants

Attention is drawn to the fact that additional transportation regulations may exist with respect to equipment containing flammable gas. The maximum number of pieces of equipment or the configuration of the equipment permitted to be transported together will be determined by the applicable transportation regulations.

Marking of Equipment Using Signs

Signs for similar appliances used in a work area are generally addressed by local regulations and give the minimum requirements for the provision of safety and/or health signs for a work location.

All required signs are to be maintained and employers should ensure that employees receive suitable and sufficient instruction and training on the meaning of appropriate safety signs and the actions that need to be taken in connection with these signs.

The effectiveness of signs should not be diminished by too many signs being placed together.

Any pictograms should be as simple as possible and contain only essential details.

Disposal of Equipment Using Flammable Refrigerants

See national regulations.

Storage of Equipment/Appliances

The storage of the appliance should be in accordance with the applicable regulations or instructions, whichever is more stringent.

Storage of Packed (Unsold) Equipment

Storage package protection should be constructed in such a way that mechanical damage to the equipment inside the package will not cause a leak of the refrigerant charge.

The maximum number of pieces of equipment permitted to be stored together will be determined by local regulations.

General Heat Pump Information

Every heat pump system consists of a cabinet with fan assembly, electrical control box, chassis and risers, water line and condensate drain fittings. The cabinet used will vary between buildings and can be identified on the nameplate by a technician.

Standard Cabinet

The standard cabinet is a factory-assembled unit with an easily removable fan assembly. It features pre-punched knock-out openings for supply air, riser stub outs, and condensate drain connections based on specifications. To prevent vibration and noise transmission into occupant spaces, use a flexible duct connector when connecting the cabinet to supply ducts. There is no minimum height requirement for cabinet installation (hinst=0.00 ft)

ERV Cabinet

The ERV cabinet includes a built-in Energy Recovery Ventilator (ERV). This cabinet has additional openings for fresh outside air, stale air, and exhaust air, which should be installed in the same manner as the standard cabinet. The ERV is internally powered, and ERV drain flex pipes are factory-installed inside the main cabinet drain pan.

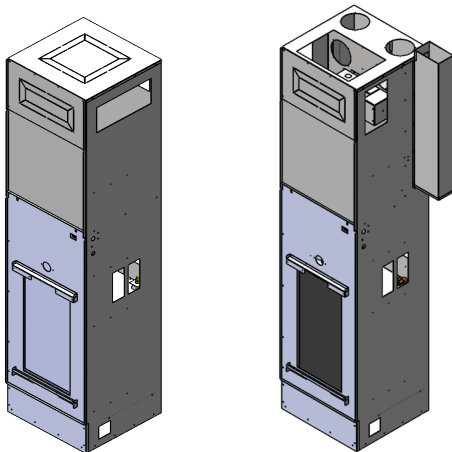

Energy Recovery Ventilator (ERV) -If Applicable

Integrated ERV cores are factory installed in the top compartment of the cabinet. ERV units are manufactured with continuous motor/blower operation in low speed.

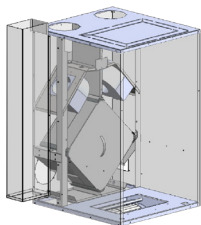

Blower & Motor Assembly

Each cabinet includes a blower and motor assembly mounted on the blower deck. This assembly can be easily removed through the return air access panel. The default Electronically Commutated Motor (ECM) is internally powered. On ERV units, the blower and motor assembly will continuously run on low speed.

Nameplate



A nameplate is located on the cabinet surface and chassis box. It contains the unit model and serial numbers, electrical data, refrigerant R454B charge, and other information. This nameplate information is useful for warranty customer service or ordering service parts. Refer to pages 6-7 for nomenclature standards.

Junction Box

A wiring diagram is located on the cabinet surface for field wiring. A non-fused disconnect is installed on the side of the cabinet.

Electrical Box

The Electrical Box includes a transformer, compressor contactor & capacitor, and Unilux HVAC proprietary microprocessor controller. The microprocessor board features an integral terminal strip for wiring the thermostat cable.

Return Air Access Panel

Unilux HVAC return air panels are perimeter-style with acoustic insulation for quiet operation.

Disclaimer



All piping work must be done by a certified plumber. Unilux HVAC is not responsible for any water damage.

Receipt, Storage, and Inspection

Arrival

When units are received at the site, carefully check for any damage incurred during shipment. If damaged, note it on the Carrier's Bill of Lading as "Damaged during Shipment" or "Received Damaged." Cross-check the packing slip against all items received. Note any missing items on the Carrier's Bill of Lading with "Shipment Received Less Item # ____."

Storage

Store equipment in its original packaging as shipped (horizontal or vertical) on their pallets for protection in a clean, dry area. Do not stack the units. **Always keep chassis in an upright position to maintain POE oil inside the compressor.** Do not lean or rest on risers and don't use risers for lifting. Use a waterproof tarp or equivalent covering if necessary to protect units from humid or high UV areas.



Caution: Avoid storing or installing units in corrosive environments or areas exposed to extreme temperatures or humidity (such as rooftops, garages, etc.). These conditions can greatly diminish performance, reliability, and the lifespan of the units.

Always transport and store chassis in an upright position; laying them on their sides can result in equipment damage. Chassis should be stored in climate controlled environment to prevent freezing



Caution: Physical damage or contamination can hinder unit start-up and cause equipment damage. Protect units at the job site by covering them with the original packaging or an equivalent protective covering and cap the open ends of pipes. Ensure all cabinet openings are covered throughout all stages of construction.

Pre-Installation Preparation

Read all provided Installation, Operation, and Maintenance (IOM) instructions and attached drawings before installation and unit start-up. Perform the following steps before proceeding to installation:



Note: Each installation is unique and may necessitate additional steps or adjustments to this Installation, Operation, and Maintenance (IOM) manual. Always follow the specific IOM instructions and drawings provided for each installation.



Caution: Keep all cabinet openings covered until the unit installation is complete and all surrounding work (including drywalling, painting, etc.) is finished.

- Verify that the unit nameplate matches the floor plan and ensure the power supply and breaker meet the requirements on the nameplate. Ensure the electrical data on the unit nameplate matches the ordering and shipping information.
- Perform a visual inspection of the cabinet, riser ends, chassis, and accessories to ensure they are not damaged and there is no debris inside the cabinet, chassis, or hoses.
- Verify the cabinet's supply air openings match the size and location specified in the building plans. If the unit is not factory configured with cabinet knockouts for supply air openings, remove the required knockouts, and cut the cabinet insulation. Do not remove unused knockouts. Ensure they are securely covered.
- For cabinets shipped without risers, remove the required riser knockouts and make a vertical slit down the center of the insulation slot without removing the insulation. If you encounter any torn insulation, repair it using foil tape.
- For chassis shipped inside cabinets, remove and discard 2 shipping bolts in filter panel. Remove side brackets from chassis.
- Inspect the chassis refrigerant tubing to ensure it is free from kinks or dents and does not come into contact with other tubes or parts of the chassis as it routes over or through them. Adjust if necessary and use closed-cell insulation for separation.
- Check all electrical connections on the chassis. Ensure that each connection is clean and firmly secured at the terminals.



Warning: Sheet metal components often have sharp edges or burrs. Exercise caution and wear suitable protective gear, including safety glasses and gloves, during installation and while handling all heat pump components including the cabinet.

Installation



Warning: To avoid electrical shorts and leaks in the drain pan, do not let screws penetrate any parts of the unit, especially when inserting screws near the control box or drain pan. Do not allow screws or nails penetrate the chassis, risers, or electrical junction boxes. Ensure wall opening matches installation instructions and that screws or nails do not obstruct the removal of the chassis.



Note: All Unilux HVAC Heat Pumps have a maximum installation altitude of 3048 meters (10,000 feet).

Risers



Note: Risers come in lengths up to 140" (3555 mm). The contractor is responsible for providing any additional piping that may be required beyond this maximum length. Supply and return risers will be straight, bottom capped, or top capped. Condensate drain risers will be straight or top capped.

Risers are typically shipped attached to the heat pump cabinet. If ordered loose, risers are shipped in bulk separately. Crates will have layers of risers by floors, each cabinet's 3 risers (C, R, S). Complete riser stacks may be assembled, pressure tested, flushed, and filled prior to cabinet installation. Ensure building temperature remains above freezing before flushing. Walls should not be constructed until full unit installation is complete. Ensure risers are installed in the correct location and orientation.

Model 03-06 – S&R – ½" Shut Off Valve

Model 08-12 – S&R – ¾" Shut Off Valve

The condensate drain riser is always closest to the corner of the cabinet, return riser next, and supply riser in approximately the middle of the cabinet. Riser sizes and details may vary for every heat pump. Verify riser type, size, and shutoff valve size against submittal package to be sure you are installing the correct risers for each location.

Secure Riser Stack to building structure so the stack does not drop over time. Risers are designed to allow slight adjustments for aligning the stubs in cabinet openings. Risers are designed to allow for max ±1.5 inches (38 mm) of movement due to expansion and contraction. If the total calculated riser expansion exceeds 1.5 inches (38 mm) the field must provide expansion compensators. If loose, the shut-off valve must be soldered with stub outs as per industry standard and located inside of the cabinet opening.



Note: It is the installing contractor's responsibility to ensure that risers are not misplaced, assembled incorrectly, improperly brazed or modified, misaligned

at any time including post-cabinet installation, or unsupported adequately. This includes using specified expansion devices and maintaining the correct height and alignment of risers.

Typical Installation – Risers Shipped Attached to Cabinet

Starting on the lowest floor:

Cabinet/Riser Installation

1. Verify cabinet unit tag matches desired installation location. Cross-check unit size, riser configuration (C,R,S or S,R,C), and electrical information against project submittal package.
2. Ensure condensate risers are insulated. If installing a geothermal heat pump, ensure supply and return risers are also insulated.
3. Using 2 people, position cabinet in front of floor slab opening. Do not carry cabinet using risers.



Caution: Be careful not to damage the riser. At all times during installation, ensure risers do not take cabinet load. Do not allow the risers to support the cabinet.

4. Check risers end 16" (406 mm) from the bottom of the cabinet. See *Figure 1*. If not; loosen cable tie, adjust the risers as needed, and re-tighten the straps. Ensure valve connections are centered to the height of the drywall opening. See *Figure 2*.

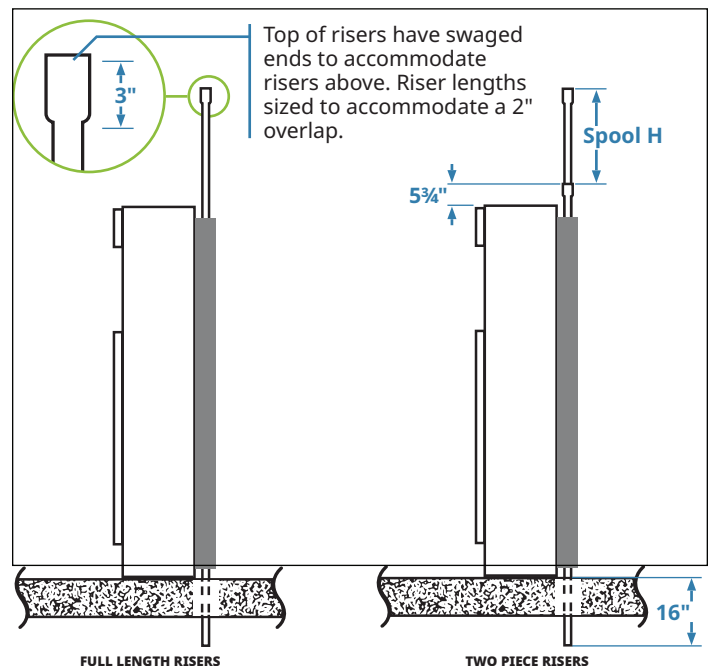

Figure 1

Installation

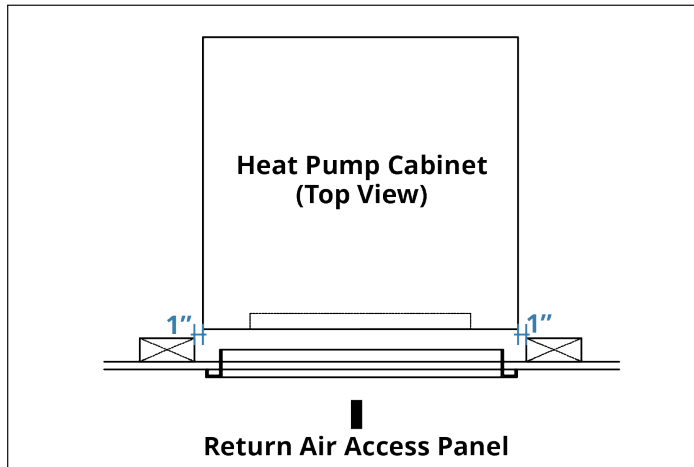

Figure 2



Note: Top of risers have swaged ends to accommodate a 2" (50 mm) overlap between floors. See *Figure 1*.

5. Raise the cabinet slowly upright while lowering the risers through the floor slab opening.

6. Ensure cabinet is centered to drywall opening with 1" (25 mm) of space to either side. See *Figure 2*.

7. If required, install riser extensions (supplied by others).

8. Neoprene isolation pads are recommended to reduce unit vibration. If supplied by contractor, place pads underneath the cabinet.



Note: If an isolation pad is placed under the cabinet, it will alter the dimensions of overlapping risers on the first floor. Ensure that the installation instructions are adjusted to account for the height of the pads.

9. Install and connect the supply ducts, discharge grilles, and any optional ductwork for remote Energy Recovery Ventilator (ERV) or Heat Recovery Ventilator (HRV) systems.

10. If unit is equipped with integrated ERV, install and connect fresh outside air intake (OA), exhaust air intake from bathroom (EI), and exhaust air to outside (EO) openings.

11. Verify that the blower wheel spins freely without obstruction.

12. Ensure there is no air short cycling occurring from any knockout openings or loose duct connections.



Caution: Do not directly attach sheet metal ductwork to the cabinet. Use a canvas-type flexible duct joint to connect the cabinet and ductwork when supply air is ducted from unit.

When all cabinets/risers on bottom floor are complete, move to next floor:

13. Repeat steps 1-4.

14. Mark risers 1.5" (38 mm) and 2" (50 mm) from the bottom.

15. Raise the cabinet slowly upright while lowering risers through the floor slab opening.

16. Ensure cabinet is centered to drywall opening with 1" (25 mm) of space to either side. See *Figure 2*.

17. If required, install riser extensions (supplied by others).

18. If supplied, place neoprene pads underneath the cabinet.

19. Align the risers to the matching swaged section of the risers on the floor below.

20. Verify that all riser joints are vertically aligned and that risers penetrate between the two marks made in step 15 into the swaged joint of the riser below. Do not let riser joint bottom out. Cut riser or use an extension if needed.



Caution: Risers must not fully settle into the swedge joint below. Avoid sliding the riser up or down on the cabinet.

21. Repeat steps 9-13 to finish installing cabinet.

22. Braze riser joints with a high-temperature alloy (such as Phos-copper or Silfos). Soft solder low-temperature alloys are not suitable for this application.



Caution: Make sure shutoff handles are parallel with riser entry side of cabinet before brazing stack.

23. Securely anchor riser stacks to the building structure with at least one contact point. Typically, at middle floors as needed. Example: a 40-floor building would be anchored at floors 10, 20, and 30. To accommodate vertical expansion and contraction, use expansion devices between anchors. Do not fasten risers rigidly within the unit. Riser anchoring is the responsibility of the project engineer or installing contractor.

Installation

24. Confirm that all unit shut-off valves are closed. Do not open valves until the system has been thoroughly cleaned and flushed.

Repeat process for all floors in building. Continue to section “Finishing the Riser Stack” to complete installation.

Installing Risers When Shipped Loose

Starting on the lowest floor:

1. Verify risers match desired installation location. Cross-check riser dimension and configuration (C,R,S or S,R,C) against project submittal package.
2. Ensure condensate risers are insulated. If installing a geothermal heat pump, ensure supply and return risers are also insulated.
3. Center risers in slot. Ensure risers will end 16” (406 mm) from the bottom of the cabinet. Note: Top of risers have swaged ends to accommodate a 2” (50 mm) overlap between floors. See *Figure 1*.
4. If required, install riser extensions (supplied by others).

Move to next floor:

5. Repeat steps 1-4.
6. Mark risers 1.5” (38 mm) and 2” (50 mm) from the bottom. Align and place the risers to the matching swaged section of the risers on the floor below.
7. Ensure all risers are vertically aligned. Verify top risers penetrate between the two marks made in step 6. Do not let riser joint bottom out. Cut riser or use an extension if needed.



Caution: Risers must not fully settle into the swedge joint below. Avoid sliding the riser up or down on the cabinet.

8. Braze riser joints with a high-temperature alloy (such as Phos-copper or Silfos). Soft solder low-temperature alloys are not suitable for this application.



Caution: Make sure shutoff handles are parallel with riser entry side of cabinet before brazing stack.

9. Securely anchor riser stacks to the building structure with at least one contact point. Typically, at middle floors as needed. Example: a 40-floor building would be anchored at floors 10, 20,

and 30. To accommodate vertical expansion and contraction, use expansion devices between anchors. Do not fasten risers rigidly within the unit.

10. Confirm that all unit shut-off valves are closed. Do not open valves until the system has been thoroughly cleaned and flushed.

Repeat process for all floors in building. After all risers are installed, move on to “Installing Cabinets When Risers Shipped Loose”.

Installing Cabinets When Risers Shipped Loose

1. Verify cabinet unit tag matches desired installation location. Cross-check unit size, riser configuration (C,R,S or S,R,C), and electrical information against project submittal package.
2. Using 2 people, position cabinet in front of floor slab opening and connect P-trap.
3. Ensure cabinet is centered to drywall opening with 1” (25 mm) of space to either side. Ensure riser valves are in the centre of slot and inside cabinet by 1”.
4. Neoprene isolation pads are recommended to reduce unit vibration. If supplied by contractor, place pads underneath the cabinet.



Note: If an isolation pad is placed under the cabinet, it will alter the dimensions of overlapping risers on the first floor. Ensure that the installation instructions are adjusted to account for the height of the pads.

5. Install and connect the supply ducts, discharge grilles, and any optional ductwork for remote Energy Recovery Ventilator (ERV) or Heat Recovery Ventilator (HRV) systems.
6. If unit is equipped with integrated ERV install and connect outside air, stale air, and exhaust air openings.
7. Verify that the blower wheel spins freely without obstruction.
8. Ensure there is no air short cycling occurring from any knockout openings or loose duct connections.



Caution: Do not directly attach sheet metal ductwork to the cabinet. Use a canvas-type flexible duct joint to connect the cabinet and ductwork when supply air is ducted from unit.



For appliances using A2L refrigerants, connected via an air duct system to one or more rooms, the supply and return air shall be directly ducted to the space. Open areas such as false ceilings shall not be used as

Installation

a return air duct.

Repeat process for all floors in building. Continue to “Finishing the Riser Stack”.

Finishing the Riser Stack

Once the riser system installation in the building is complete, it must be flushed, cleaned, and chemically treated prior to connecting it with the chassis. Ensure that the riser system is not flushed and cleaned while the chassis units are connected. You may proceed with the chassis installation only after the riser system has been thoroughly flushed, cleaned, and properly commissioned.

1. Conduct a pressure test on the riser to identify and repair any leaks.
2. Check the condensate drain - clean the pan if needed. Slowly pour 1 to 2 quarts (1 to 2 litres) of water into the pan. Water should drain freely. Check for water in the cabinet and on the floor. Repair if needed.
3. Repair and replace any damaged or missing riser insulation. If extensions are used, repair and replace any that are damaged or missing.
4. Install a drain valve, shut-off/balancing valve, flow indicator, and drain tee at the base of each supply and return riser stack.
5. Install a strainer at the inlet of each circulating pump.



Caution: Before flushing the riser system, ensure the building temperature is kept above freezing.

6. To ease cleaning and flushing, install a hose kit at the point farthest from the pump and connect the ends of the hoses with a riser flush adapter. Ensure all hoses are connected end to end before flushing so debris does not enter the unit's heat exchanger, water valves, or other components. Open both valves to start flushing the system with fresh, potable water that is free of dirt, pipe residue, and harsh chemicals. Once the system is thoroughly cleaned, close the valves and remove the flush adapter before proceeding with the chassis installation.



Note: Unilux HVAC supplied hoses are not intended to connect supply and return risers or used to flush system. System flushing hoses are provided by contractor.

7. Place air vents at the highest accessible point within the piping loop to allow for the release of any air trapped during installation. Ensure that all air is completely expelled from the system. Remaining air can lead to inefficient operation or even corrosion within the system.

After successful completion and flushing of the riser system, you may install the chassis in each cabinet.

Chassis Installation

1. Fully unpack the chassis and place it in front of the cabinet.
2. Verify that the chassis model matches the cabinet model tag number.
3. Remove the filter panel from cabinet. Loosen bolt--do not remove.
4. On ERV unit, ensure ERV drain lines are to side of chassis, not behind.
5. Align the back of the chassis with the cabinet rails.
6. Attach the condensate float switch to the inner side of the drain pan.
7. Lift and partially slide the chassis into the cabinet until it rests on the rail without additional support.
8. Connect the hoses by hand, then carefully tighten fittings to avoid damaging the water lines (max torque for ½" hose is 40 ft lbs; max torque for ¾" hose is 55 ft lbs + 10%-0). Use a wrench to hold the valve steady and a torque wrench to tighten the nut.
9. Ensure the water-in hose is connected to the supply riser and the water-out hose is connected to the return riser.
10. In the operational riser loop, open the shut-off valves and inspect all connection points for any water leaks.
11. Connect the wiring harness plugs for the motor/blower assembly and the chassis main power.
12. Connect the thermostat wire to the t-stat terminal block on circuit board located inside chassis control box. Refer to thermostat supplier's manual for detailed installation instructions.
13. Check that the capillary tubes and headers are not in contact with anything. Separate if needed. Check that the wiring harnesses and hoses are not pinched. Slide the chassis fully inside the cabinet, taking care not to push against the coil surface.

Installation

14. Reinstall the filter panel on the cabinet. **Ensure bottom of filter panel is inside drain pan. Install 4 - #8x½" drill / tap screws on each side of filter panel through holes provided (screws field supplied).**
15. Ensure the foam gasket on the filter panel seals tightly around the perimeter of the coil frame, avoiding any contact with the coil fins.
16. Install the filter on the front of the filter panel.
17. Install the access panel into the drywall opening.



Warning: To prevent unit damage or failure due to clogged coil surfaces or ventilation openings and stalled fan blades, ensure you do not operate the unit without completing the cabinet assembly including supply grille, filter panel, and access panel. See **Figure 3** for component diagram.

Drywall Installation



Note: Unilux HVAC is not liable for wallboard repair if junction box is improperly orientated.



Caution: Do not attach drywall studs to the cabinet.

If installing a Unilux HVAC Thermostat, ensure the 2" x 2" junction box is installed before installing the drywall. Adjust its position as necessary. For installations involving a different thermostat model, please consult the supplier's IOM.

For optimal sound attenuation, avoid attaching studs or drywall directly to the cabinet. Instead, install studs and drywall using standard construction methods. Do not install drywall using adhesive alone – use low-profile, pan-head sheet metal screws to secure drywall to studs. See **Figures 4 and 5** to determine stud layouts and dimensions from the cabinet to the finished wall. After cutting out supply and return holes for grilles, vacuum all drywall dust and construction debris from the cabinet insulation, drain pans, and blower discharge plenum. For optimal sound attenuation, place insulation between the drywall and the cabinet.

Once installation is complete, cover all cabinet openings and exposed sheet metal. Do not allow paint or wall texture overspray to encounter insulation, sheet metal, coils, motor/blower assembly, or any other unit components. Unit warranty will be voided if paint or other foreign debris contaminates internal unit components.

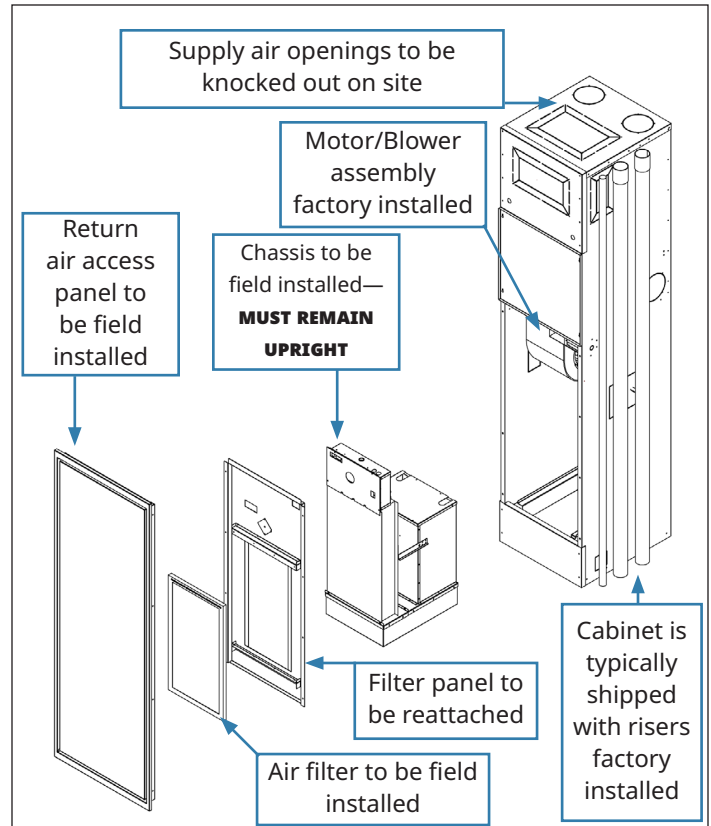

Figure 3

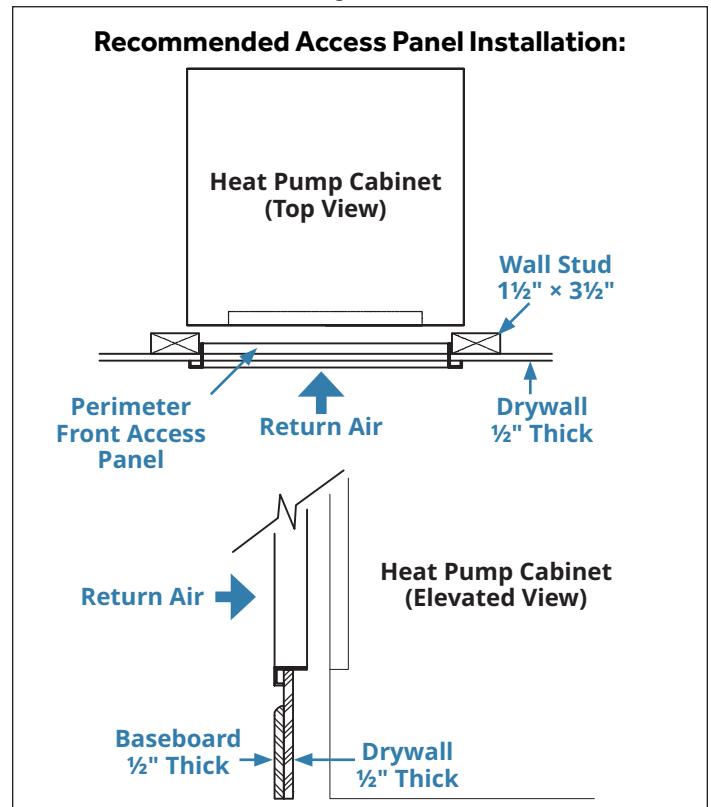

Figure 4

Installation

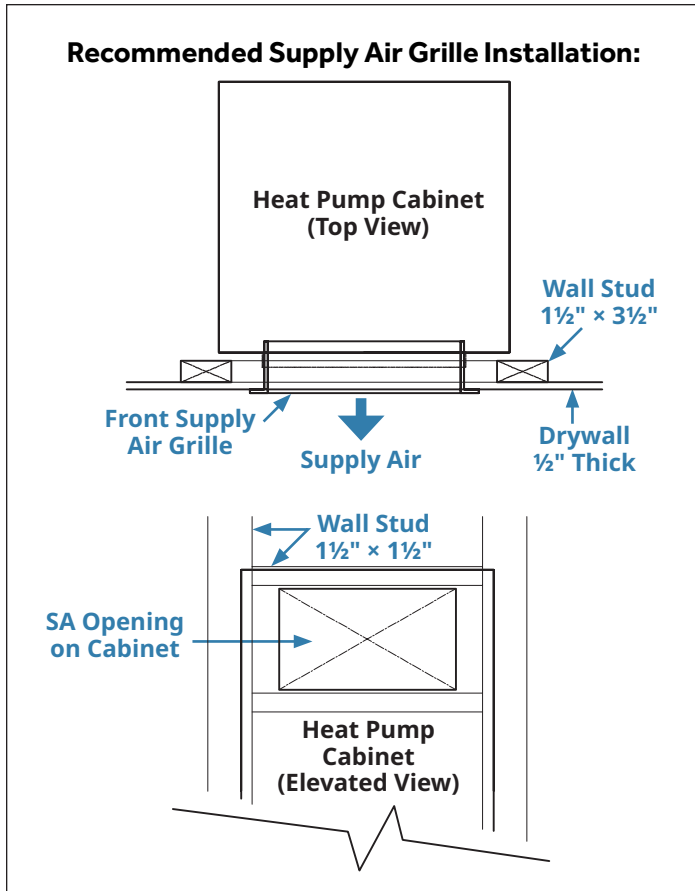

Figure 5

Hoses

Piping Installation

A condensate drain line must be attached to the unit's drain pan connection. The condensate drain line should be pitched away from the unit at 1/8" per foot. **At no point should any part of the condensate drain line be installed above the heat pump drain pan connection.** It is up to the contractor to install all piping in accordance to applicable laws and regulations.

Supply and return piping is joined to the heat pump with short lengths of high pressure flexible hose. Unilux HVAC hose kits include two braided steel covered flex hoses for water in and water out. Hose sizes are based on the unit model - see right.



Caution: Do not connect the unit to supply and return piping until the water system has been fully flushed out. A high point of the piping system must be vented.



Note: Unilux supplied hoses are not intended to connect supply/return risers or used to flush system. All piping work must be done by a certified plumber.

Unilux HVAC is not responsible for any water damage.



Caution: All Unilux HVAC vertical stack heat pump models have a maximum water operating pressure of 360psig and minimum water operating pressure of 40psig.

Flex Hose Kit—Models UVHP02-06L / UVHH02-06L



1/2" hose available in 24" length. Connects to shut-off valve installed on riser with ball valve. Dry seal only. Do not use teflon tape or pipe dope.

Torque both ends of flex hose to 40 + 10% - o ft lbs.

Working Pressure: 400 PSI

Burst Pressure: 1600 PSI

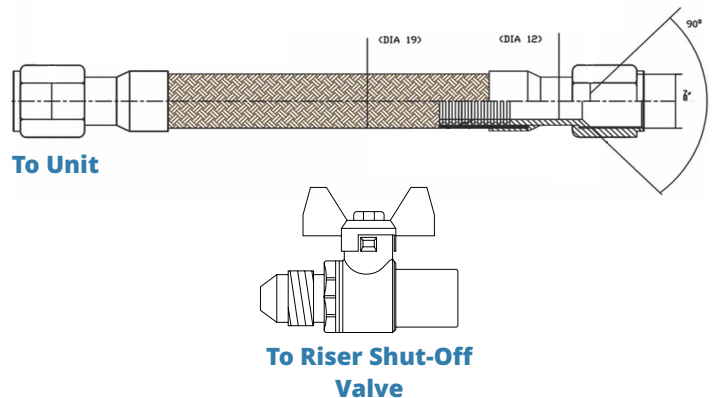

Flex Hose Kit—Models UVHP08-12L / UVHH08-12L



3/4" hose available in 24" length. Connects to shut-off valve on riser with ball valve. Dry seal only. Do not use teflon tape or pipe dope.

Torque both ends of flex hose to 55 + 10% - o ft lbs.

Working Pressure: 400 PSI

Burst Pressure: 1600 PSI

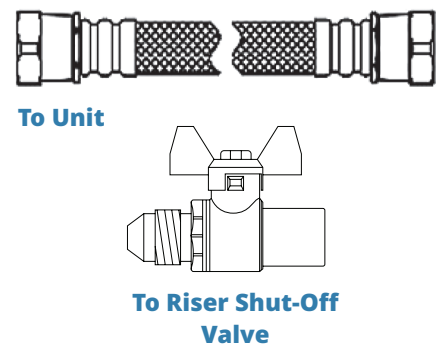

Heat Pump Pre-Commissioning Checklist

System Checklist

Verify and submit documentation confirming that the following has been completed:

All Jobs

Water Treatment

As Required

Boiler Commissioning

Cooling Tower Commissioning

OR

Geothermal Loop Commissioning

Safety Checks



- Verify the building water loop system has been cleaned, flushed, and chemically treated as per the industry standard and the loop is complete with strainer or filtration system. In order to maintain your warranty, the closed loop system must be kept clean and monitored on a regular basis ensuring PH (8.5-10.5) and ammonia (< 5.0 PPM) remain within acceptable levels. Ensure building riser system is purged of all remaining air.
- Heat pump unit should be at room temperature (68°F/20°C) for 48 hours before start-up. Failure to do so will damage unit.

Note: All following steps must be completed to avoid equipment damage.

Pre-Startup Checklist

- Cabinet model number matches with chassis model number
- The power supply voltage matches what is specified on the nameplate
- Electrically grounded & circuit protection is correct
- Control wiring is correct as per electrical schematic
- The disconnect switch is in **OFF** position
- The thermostat is in off mode and wires are connected correctly
- Thermostat wiring block is plugged in to the correct location.
- Ensure that all shipping materials and debris have been removed from cabinet and the surrounding area is clean with no obstructions
- A clean filter is installed in the right direction
- Riser shut-off valves are in the **OPEN** position
- Ensure filter panel is installed correctly with a proper seal between chassis and filter panel. If there are gaps, correct as necessary (ex. adjust chassis, use foil tape or additional gasket, etc.) Ensure the bottom of filter panel is installed inside drain pan. Install 4- #8x½" drill/tap screws through each side of the filter holes provided (screws field supplied)
- Ensure riser openings are properly sealed to prevent air bypass

Important: All units must be turned on and commissioned by an authorized Unilux HVAC technician. Failure to comply will void the unit's warranty agreement.

| | | | |
|---------------------------|--|----------------------------|--|
| Job Name | | Mechanical Contractor Name | |
| Date | | Contractor Contact Name | |
| Requested Commission Date | | Signature | |

Operating Limits

UVHPL/UVHPL-ERV

| EAT (Entering Air Temp) Limits | | | |
|--------------------------------|-------------|-------------|-------------|
| | Cooling | | Heating |
| | DB | WB | DB |
| EAT Std. | 75°F / 24°C | 63°F / 17°C | 68°F / 20°C |
| EAT Min. | 65°F / 18°C | 55°F / 13°C | 50°F / 10°C |
| EAT Max. | 85°F / 29°C | 71°F / 22°C | 80°F / 27°C |

| EWT (Entering Water / Fluid Temp) Limits | | |
|--|--------------|-------------|
| | Standard | |
| | Cooling | Heating |
| EWT Std. | 86°F / 30°C | 68°F / 20°C |
| EWT Min. | 50°F / 10°C | 55°F / 13°C |
| EWT Max. | 110°F / 43°C | 90°F / 32°C |

| Air Volume Limits | |
|-------------------|-----|
| Min. CFM / Ton | 350 |
| Design CFM / Ton | 450 |

| Fluid Flow Limits | |
|-------------------|-----|
| Min. GPM / Ton | 1.5 |
| Design GPM / Ton | 3.0 |
| Max. GPM / Ton | 3.5 |

UVHHL/UVHHL-ERV

| EAT (Entering Air Temp) Limits | | | |
|--------------------------------|-------------|-------------|-------------|
| | Cooling | | Heating |
| | DB | WB | DB |
| EAT Std. | 75°F / 24°C | 63°F / 17°C | 68°F / 20°C |
| EAT Min. | 65°F / 18°C | 55°F / 13°C | - |
| EAT Max. | 85°F / 29°C | 71°F / 22°C | - |

| EWT (Entering Water/Fluid Temp) Limits | | |
|--|--------------|---------------------|
| | Standard | |
| | Cooling | Heating |
| EWT Std. | 86°F / 30°C | 105–110°F / 41–43°C |
| EWT Min. | 50°F / 10°C | 100°F / 38°C |
| EWT Max. | 110°F / 43°C | 180°F / 82°C |

| Air Volume Limits | |
|-------------------|-----|
| Min. CFM / Ton | 350 |
| Design CFM / Ton | 450 |

| Fluid Flow Limits | |
|-------------------|-----|
| Min. GPM / Ton | 1.5 |
| Design GPM / Ton | 3.0 |
| Max. GPM / Ton | 3.5 |



Air, water/fluid operating, or design limits can't be combined. Combination of maximum and minimum limits are not allowed. Perform one change at a time, either water/fluid side **or** air side.

Operating Limits

UVHPL-G / UVHPL-G-ERV

| EWT (Entering Water / Fluid Temp) Limits—Glycol | | |
|---|--------------|-------------|
| | Standard | |
| | Cooling | Heating |
| EWT Std. | 85°F / 29°C | 60°F / 16°C |
| EWT Min. | 30°F / -1°C | 20°F / -7°C |
| EWT Max. | 110°F / 43°C | 90°F / 32°C |

| Fluid Flow Limits | |
|-------------------|-----|
| Min. GPM / Ton | 2.0 |
| Design GPM / Ton | 3.0 |
| Max. GPM / Ton | 3.5 |

| Correction Factors: Ethylene Glycol | |
|-------------------------------------|----------------|
| Glycol | Total Capacity |
| 0% | 1 |
| 10% | 0.96 |
| 15% | 0.946 |
| 20% | 0.932 |
| 25% | 0.912 |
| 30% | 0.898 |
| 35% | 0.877 |
| 40% | 0.855 |
| 45% | 0.828 |
| 50% | 0.8 |

| Correction Factors: Propylene Glycol | |
|--------------------------------------|----------------|
| Glycol | Total Capacity |
| 0% | 1 |
| 10% | 0.998 |
| 15% | 0.971 |
| 20% | 0.962 |
| 25% | 0.949 |
| 30% | 0.936 |
| 35% | 0.919 |
| 40% | 0.901 |
| 45% | 0.877 |
| 50% | 0.853 |

| Freezing Temperature (F) | | | | | | | | | | |
|--------------------------|----|-----|------|------|-----|-----|-----|-------|-----|-------|
| Glycol | 0% | 10% | 15% | 20% | 25% | 30% | 35% | 40% | 45% | 50% |
| Ethylene | 32 | 25 | 21 | 16 | 10 | 4 | -3 | -12.5 | -23 | -34.5 |
| Propylene | 32 | 26 | 22.5 | 18.5 | 14 | 8 | 2 | -6 | -17 | -29 |

General Operation

Commax Wall Pad

1. Works with Commax wall-pad with Protocol updated on 2023-01-10.
2. Jumper on HUM2 connector on PIN2&3 is required.

DIP SW settings

Table 1

| DIP SW | OFF | ON |
|----------|---------------------|---------------------|
| DIP SW 1 | Regular Heat pump | Hybrid Heat pump |
| DIP SW 2 | 35F freeze temp EWT | 20F freeze temp EWT |
| DIP SW 3 | Refer Table 2 | Refer Table 2 |
| DIP SW 4 | Refer Table 2 | Refer Table 2 |

Table 2

| DIP SW3 | DIP SW 4 | Board number |
|---------|----------|--------------|
| 0 | 0 | 1 |
| 0 | 1 | 2 |
| 1 | 0 | 3 |
| 1 | 1 | 4 |

Note: Unilux control board can run 4 heats pumps with single Commax walpad. DIP SW need to adjust as shown above.

Commax wall-pad System Mode ON/OFF

Commax wall-pad has OFF feature to turn OFF complete system operation. OFF feature will turn OFF heating/cooling, including FAN (except with ERV/HRV). However, all safety sensors and protective feature will stay active.

Commax wall-pad Error display

Moderate Error: If room sensor is not connected, or damaged during installation or over time it will show moderate error on wall-pad display.

Severe Error: HP, LP, DP, FZ or FZ water temp error activation will trigger severe error on wall-pad display.

API responses: 7F API communication

Table 2

| | | |
|----------|----------------------------|----------|
| Byte 0 | D7 | Command |
| Byte 1 | N/U | BCD in C |
| Byte 2 | Entering Water Temperature | BCD in C |
| Byte 3 | Leaving Water Temperature | 00 |
| Byte 4 | N/U | 00 |
| Byte 5 | N/U | 0/1 |
| Byte 6.7 | DP Error | 0/1 |
| Byte 6.6 | HP Error | 0/1 |
| Byte 6.5 | LP Error | 0/1 |
| Byte 6.4 | FP Error | 0/1 |
| Byte 6.3 | Water Temp Error | 0/1 |

| Num | Byte 6.0 | Byte 6.1 | Byte 6.2 | Comment |
|-----|----------|----------|----------|---|
| 0 | 0 | 0 | 0 | RV: OFF, Compressor: OFF, Coax: OFF |
| 1 | 0 | 0 | 1 | RV: OFF, Compressor: OFF, Coax: ON |
| 2 | 0 | 1 | 0 | RV: OFF, Compressor: ON, Coax: OFF |
| 3 | 0 | 1 | 1 | RV: OFF, Compressor: ON, Coax: ON |
| 4 | 1 | 0 | 0 | RV: ON, Compressor: OFF, Coax: OFF |
| 5 | 1 | 0 | 1 | RV: ON, Compressor: OFF, Coax: ON |
| 6 | 1 | 1 | 0 | RV: ON, Compressor: ON, Coax: OFF |
| 7 | 1 | 1 | 1 | RV: ON, Compressor: ON, Coax: ON |

System Default setting and EEPROM memory configuration

- Initial system startup when system turns ON for first time it will set on as follow:
 - System Mode: ON
 - Operation Mode: General
 - HVAC Mode: Heat
 - General Temperature: 23C, Away Temperature: 20C
 - Fan Mode: Auto
- EEPROM setting: System Mode, Operation Mode, HVAC mode, General Temp, Away Temp and Fan Mode is saved in internal EEPROM memory every 10 sec. Any changed setting will save after 10 sec in EEPROM.

Commax Communication Protocol

Command

| | | |
|---------|---------------|-------------------|
| Byte 00 | Command | 52 |
| Byte 01 | Board Address | 1-40 |
| Byte 02 | | |
| Byte 03 | | |
| Byte 04 | | |
| Byte 05 | | |
| Byte 06 | | |
| Byte 07 | Check Sum | Byte 0 +..+Byte 6 |

Response

| | | |
|---------|----------------|-------------------|
| Byte 00 | Command | D2 |
| Byte 01 | Control Status | |
| Byte 02 | Temp Gen | |
| Byte 03 | Temp Away | |
| Byte 04 | Current Temp | |
| Byte 05 | HVAC Mode | |
| Byte 06 | FAN Mode | |
| Byte 07 | Check Sum | Byte 0 +..+Byte 6 |

Command

| | | |
|---------|-----------------|-------------------|
| Byte 00 | Command | 53 |
| Byte 01 | Board Address | 1-40 |
| Byte 02 | Type of Control | |
| Byte 03 | Parameter 1 | |
| Byte 04 | Parameter 2 | |
| Byte 05 | | |
| Byte 06 | | |
| Byte 07 | Check Sum | Byte 0 +..+Byte 6 |

CMD 0x52: Response will be only sent after 52 commands. Firmware will read data from 0x53 command, and responds back when 0x52 command is received. Delay programmed 30mS between command and response.

CMD 0xD2: Note: Control Status – Bit 07: ON/OFF, Bit 4,5: Error, Bit 0: Away/Gen

CMD 0x53:

Case 0: Power ON & OFF (Byte 02 = 01)

Byte 03: Power Status

0x00 = Power OFF

0x80 = Power ON

Case 1: Control of Setting Temperature (Byte 02 = 02)

Byte 03: Temperature of Operation Mode (ref. Byte 04) (Format: (BCD))

Byte 04: Operation Mode

0x01 = General Mode

0x02 = Away Mode

Case 2: Change in Operation Mode (Byte 02 = 03)

Byte 03: 0x01 = Cooling

0x02 = Heating

0x03 = Ventilation

Case 3: Control of Fan Speed (Byte 02 = 04)

Byte 03: Type of Fan Speed

0x01 = Low

0x02 = Mid

0x03 = High

0x04 = Auto

0x05 = ON

Case 4: Control of Away Mode (Byte 02 = 05)

Byte 03: Status of Away Mode

0x01 = Set

0x02 = Unset

Commax Wall Pad Wiring Diagram—UVHPL-ERV

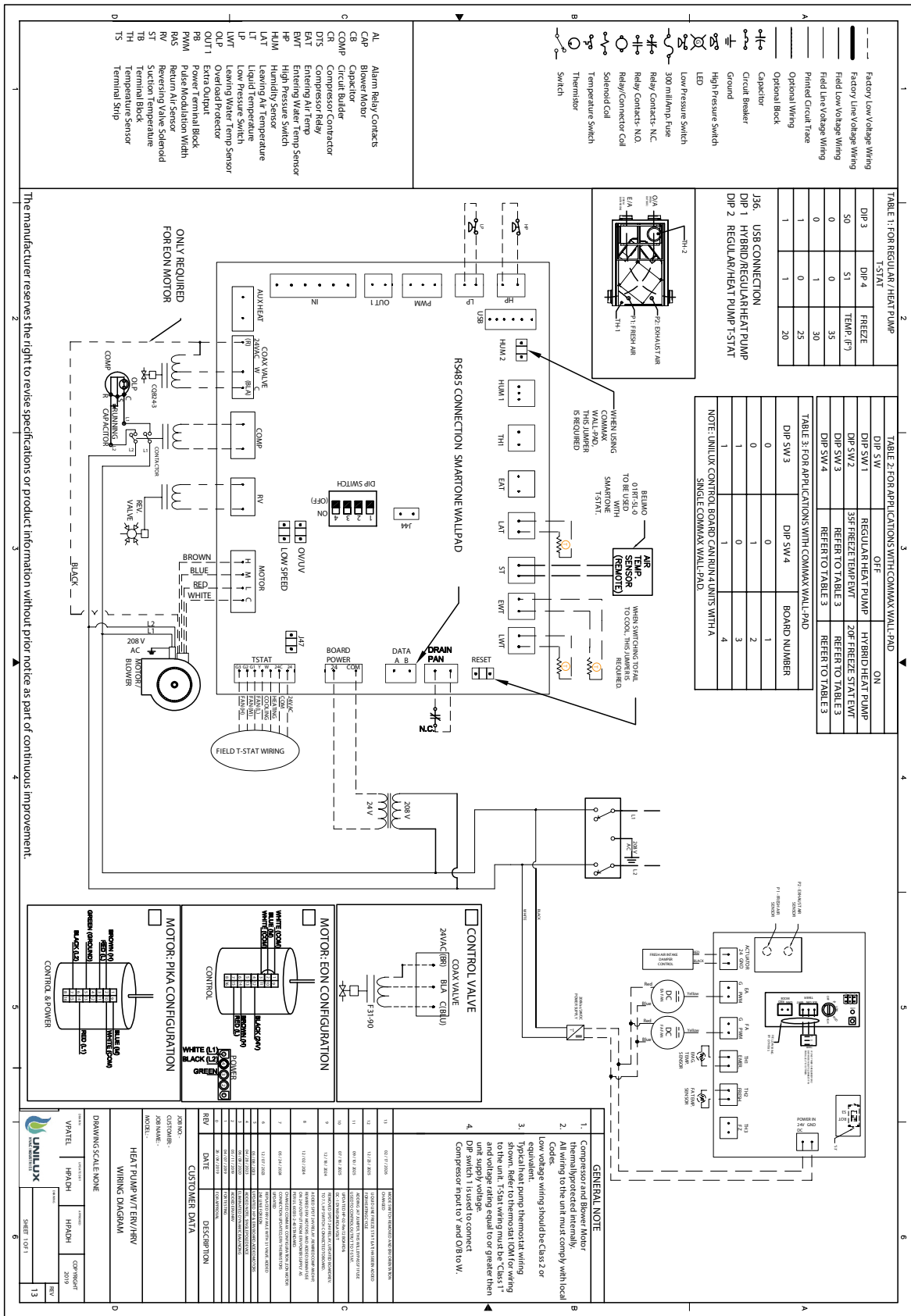

The manufacturer reserves the right to revise specifications or product information without prior notice as part of continuous improvement.

Commax Wall Pad Wiring Diagram—UVHHL

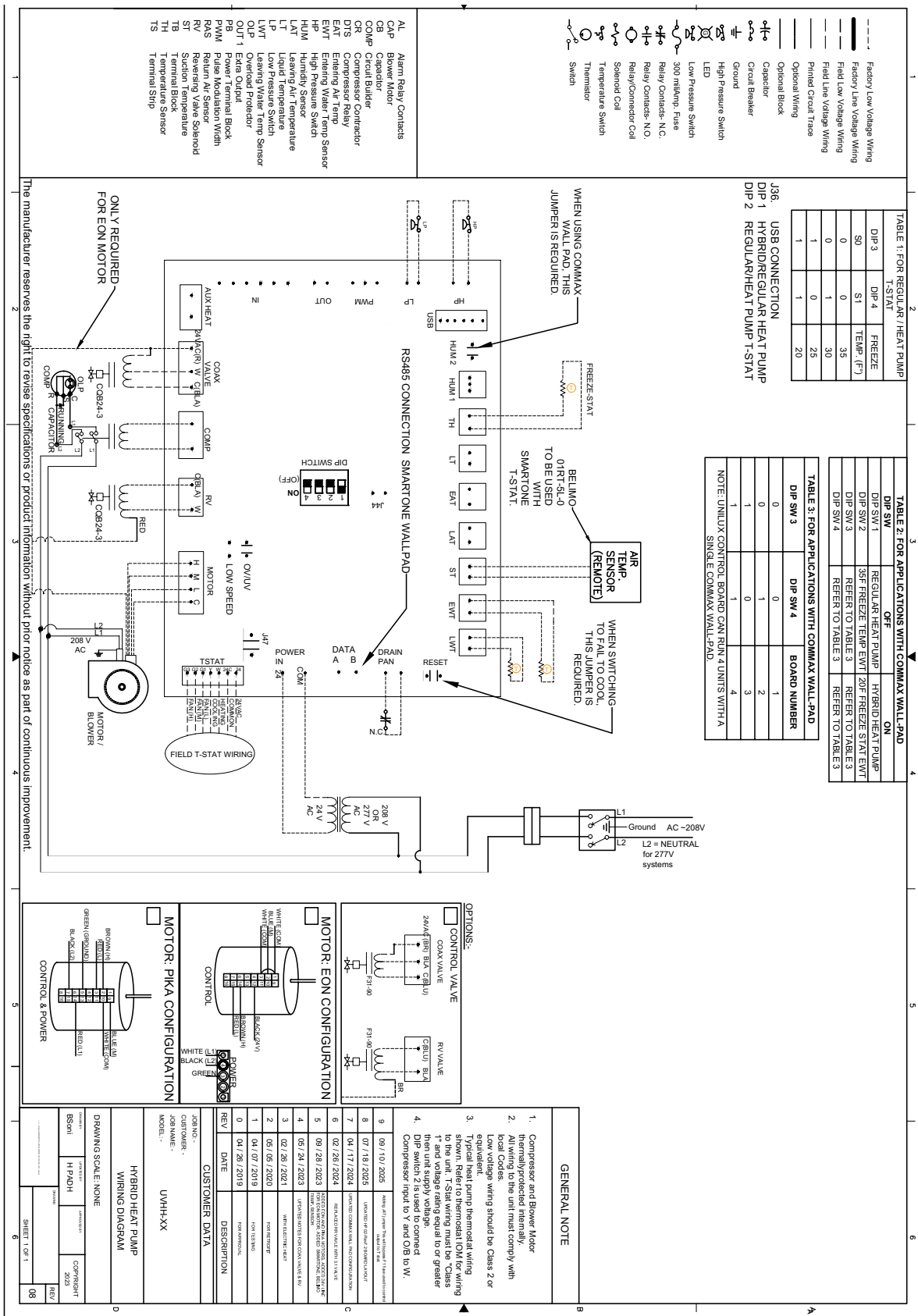

Commax Wall Pad Wiring Diagram—UVHHL-ERV

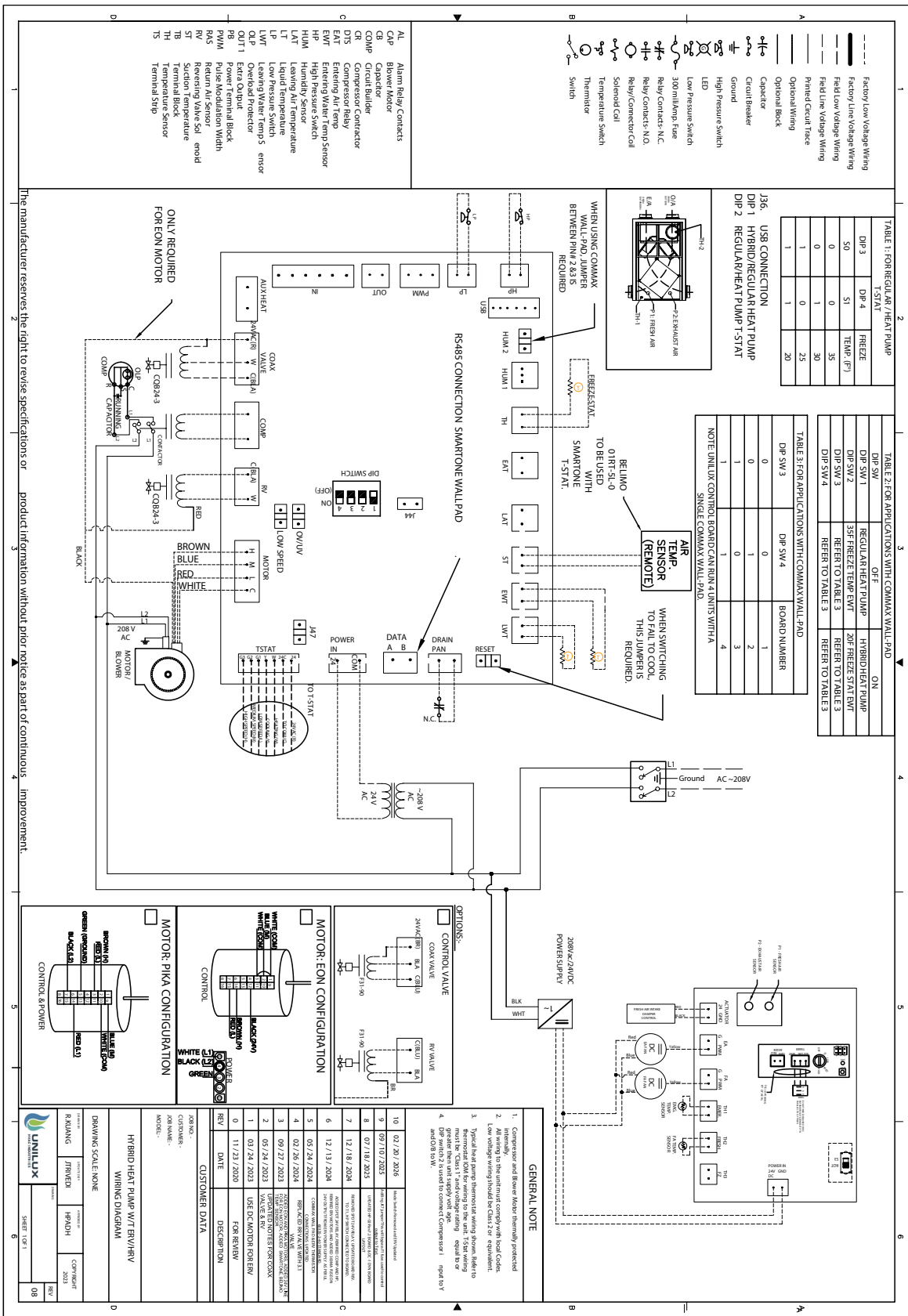

General Operation

Sequence of Operations—UVHPL/UVHPL-G (Standard fail to heat)

Call for Heat

On a call for heat from the thermostat ($T_s > T_r + 1^\circ\text{F}$)

- Reversing valve will be de-energized
- Fan turns on to high speed
- Compressor contactor will be energized if the following conditions are met:
 - ▶ Water shut-off valve is open
 - ▶ Water flow through coax exists for minimum of two minutes
 - ▶ No high pressure alarm
 - ▶ No low pressure alarm
 - ▶ No condensate overflow (drain pan) alarm
 - ▶ Compressor restart delay of seven minutes has expired
 - ▶ Water loop temp supply side (EWT) is $<110^\circ\text{F} / 43^\circ\text{C}$
 - ▶ Water loop temp discharge side (LWT) is $<122^\circ\text{F} / 50^\circ\text{C}$

After call has been satisfied ($T_r = T_s$)

- Reversing valve will continue to be de-energized
- Compressor contactor will be de-energized
- Water shut-off valve remains open
- Water shut-off valve will be flushed for three minutes
- Fan will remain on for one minute and then will turn off or return to thermostat setting
- Once above conditions are satisfied, coax flow valve is closed

Call for Cooling

On a call for cool from the thermostat ($T_s < T_r - 1^\circ\text{F}$)

- Reversing valve will be energized
- Fan turns on to high speed
- Compressor contactor will be energized if the following conditions are met:
 - ▶ Water shut-off valve is open
 - ▶ Water flow through coax exists for minimum of two minutes
 - ▶ No high pressure alarm
 - ▶ No low pressure alarm
 - ▶ No condensate overflow (Drain Pan) alarm
 - ▶ Compressor restart delay of seven minutes has expired
 - ▶ Water loop temp supply side (EWT) is $<110^\circ\text{F} / 43^\circ\text{C}$
 - ▶ Water loop temp discharge side (LWT) is $<122^\circ\text{F} / 50^\circ\text{C}$

After call has been satisfied ($T_r = T_s$)

- Reversing valve will continue to be energized
- Water shut-off valve remains open and will be flushed for three minutes
- Fan will remain on for one minute and then will turn off or return to thermostat setting
- Once above is satisfied, water shut-off valve is closed

HEATING FLOW DIAGRAM

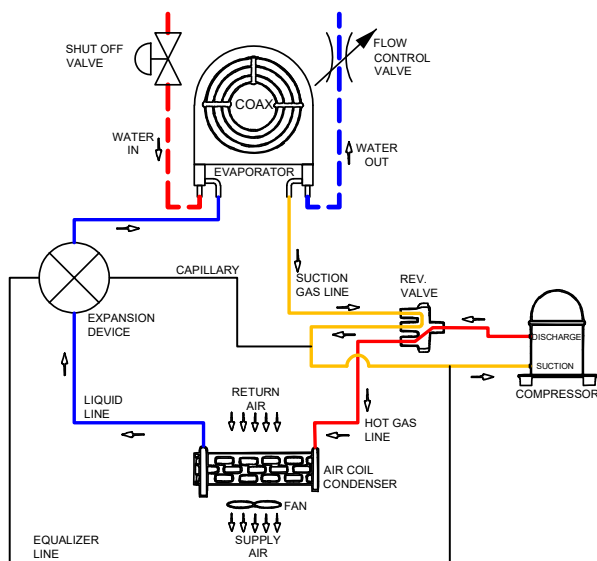

COOLING FLOW DIAGRAM

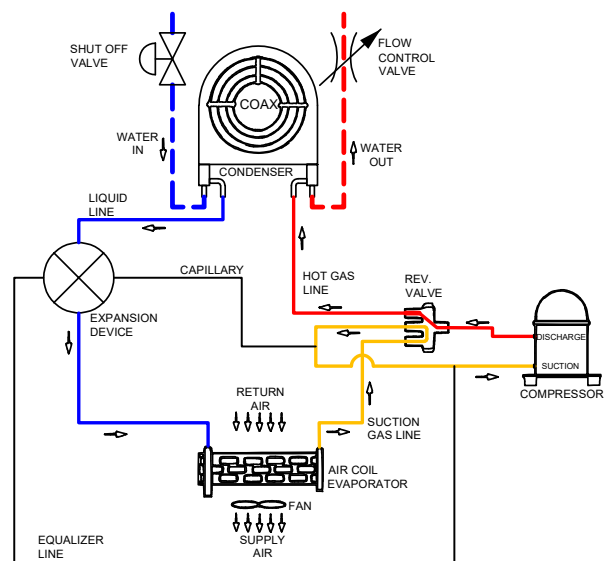

When there is no call for heat or cooling the fan is off after the Fan Off Timer interval is satisfied, except with ERV fan that runs in a continuous low speed.

Note:

1. Reversing valve should be energized in cooling and de-energized in heating.
2. Default compressor delay time from control board is 7 minutes. Additional delay may occur from the thermostat as well.
3. Fan will never run on low or off speed when compressor is ON - fan will override thermostat setting and run high speed.

General Operation

Sequence of Operations—UVHPL/UVHPL-G (Optional fail to cool)

Call for Heat

On a call for heat from the thermostat ($T_s > T_r + 1^\circ\text{F}$)

- Reversing valve will be energized
- Fan turns on to high speed
- Compressor contactor will be energized if the following conditions are met:
 - ▶ Water shut-off valve is open
 - ▶ Water flow through coax exists for minimum of two minutes
 - ▶ No high pressure alarm
 - ▶ No low pressure alarm
 - ▶ No condensate overflow (drain pan) alarm
 - ▶ Compressor restart delay of seven minutes has expired
 - ▶ Water loop temp supply side (EWT) is $<110^\circ\text{F} / 43^\circ\text{C}$
 - ▶ Water loop temp discharge side (LWT) is $<122^\circ\text{F} / 50^\circ\text{C}$

After call has been satisfied ($T_r = T_s$)

- Reversing valve will continue to be energized
- Compressor contactor will be de-energized
- Water shut-off valve remains open
- Water shut-off valve will be flushed for three minutes
- Fan will remain on for one minute and then will turn off or return to thermostat setting
- Once above conditions are satisfied, coax flow valve is closed

Call for Cooling

On a call for cool from the thermostat ($T_s < T_r - 1^\circ\text{F}$)

- Reversing valve will be de-energized
- Fan turns on to high speed
- Compressor contactor will be energized if the following conditions are met:
 - ▶ Water shut-off valve is open
 - ▶ Water flow through coax exists for minimum of two minutes
 - ▶ No high pressure alarm
 - ▶ No low pressure alarm
 - ▶ No condensate overflow (Drain Pan) alarm
 - ▶ Compressor restart delay of seven minutes has expired
 - ▶ Water loop temp supply side (EWT) is $<110^\circ\text{F} / 43^\circ\text{C}$
 - ▶ Water loop temp discharge side (LWT) is $<122^\circ\text{F} / 50^\circ\text{C}$

After call has been satisfied ($T_r = T_s$)

- Reversing valve will continue to be de-energized
- Water shut-off valve remains open and will be flushed for three minutes
- Fan will remain on for one minute and then will turn off or return to thermostat setting
- Once above is satisfied, water shut-off valve is closed

HEATING FLOW DIAGRAM

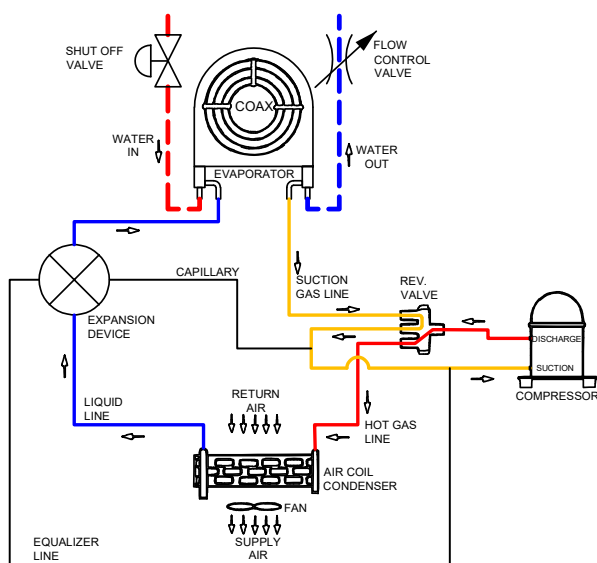

COOLING FLOW DIAGRAM

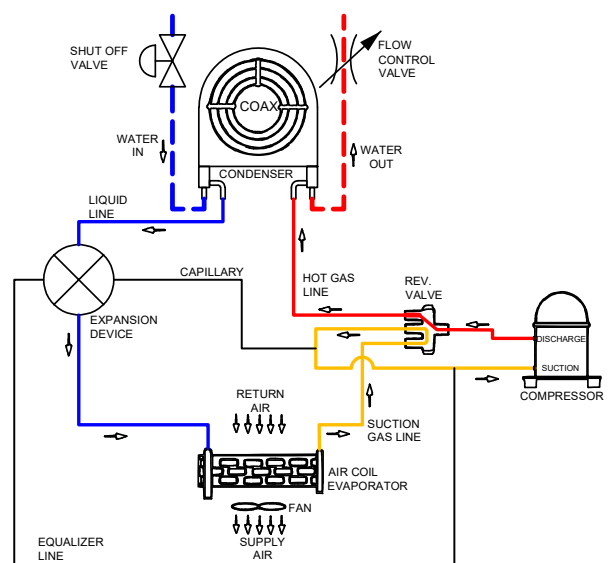

When there is no call for heat or cooling the fan is off after the Fan Off Timer interval is satisfied, except with ERV fan that runs in a continuous low speed.

Note:

1. Reversing valve should be de-energized in cooling and energized in heating.
2. Default compressor delay time from control board is 7 minutes. Additional delay may occur from the thermostat as well.
3. Fan will never run on low or off speed when compressor is ON - fan will override thermostat setting and run high speed.

General Operation

Sequence of Operations—UVHHL

Call for Heat

On a call for heat from the thermostat

- Fan turns on to high speed
- 2-way valve to hot water coil will be energized if the following conditions are met:
 - ▶ No condensate overflow (drain pan) alarm
 - ▶ No Freeze-stat alarm
 - ▶ Water loop temp supply side is $>80^{\circ}\text{F}/27^{\circ}\text{C}$

NOTE: RV (2 way valve for CONDENSER) turns ON and initiates a purge cycle (AUX also turns ON). There is no timing for purge, RV stays ON until water temp reach >80 and closes and the (2 way valve for HW Coil) COAX turns ON.

After call has been satisfied)

- 2-way valve will be de-energized
- Water shut-off valve will close
- Fan will remain on for one minute and then will turn off or return to thermostat setting

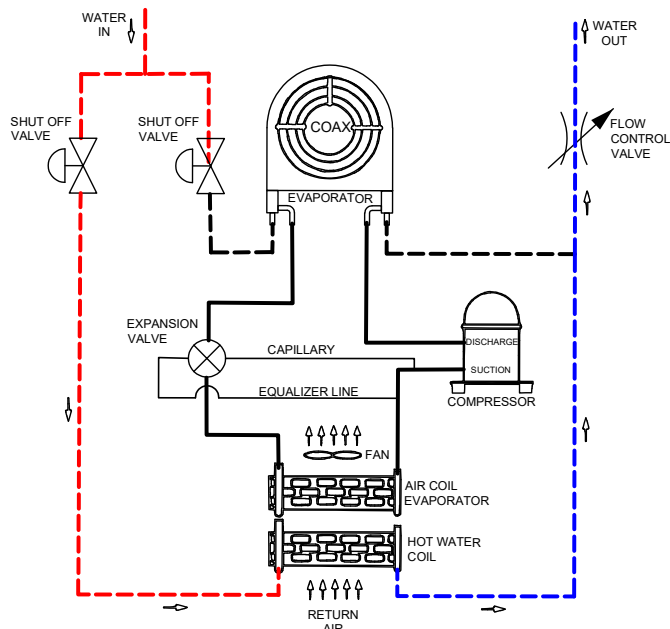

Call for Cooling

On a call for cool from the thermostat

- RV output will be energized to open water actuator
- Fan turns on to high speed
- Compressor contactor will be energized if the following conditions are met:
 - ▶ Water shut-off valve is open
 - ▶ Water flow through coax exists for minimum of two minutes
 - ▶ No high pressure alarm
 - ▶ No low pressure alarm
 - ▶ No condensate overflow (Drain Pan) alarm
 - ▶ Compressor restart delay of seven minutes has expired
 - ▶ Water loop temp supply side (EWT) is $<110^{\circ}\text{F}/43^{\circ}\text{C}$
 - ▶ Water loop temp discharge side (LWT) is $<122^{\circ}\text{F}/50^{\circ}\text{C}$

After call has been satisfied)

- Water shut-off valve remains open and will be flushed for three minutes
- Fan will remain on for one minute and then will turn off or return to thermostat setting
- Once above is satisfied, water shut-off valve is closed

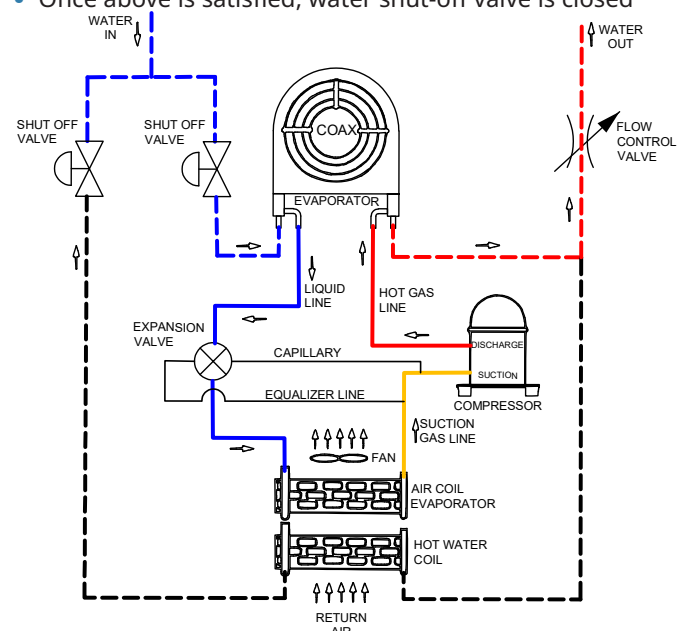

When there is no call for heat or cooling the fan is off after the Fan Off Timer interval is satisfied, except with ERV fan that runs in continuous low speed.

Note:

1. RV output should be energized in cooling and de-energized in heating.
2. Default compressor delay time from control board is 7 minutes. Additional delay may occur from the thermostat.
3. High pressure & low-pressure alarms will be disabled when the unit is on heating mode in the hybrid heat pump.
4. 2-way valve will be in an open position in the hybrid heat pump—water will flow from the water coil.
5. Fan will never run on low or off speed when compressor is ON - control board will override thermostat setting & run high speed.

General Operation

UVHHL Wiring Diagram

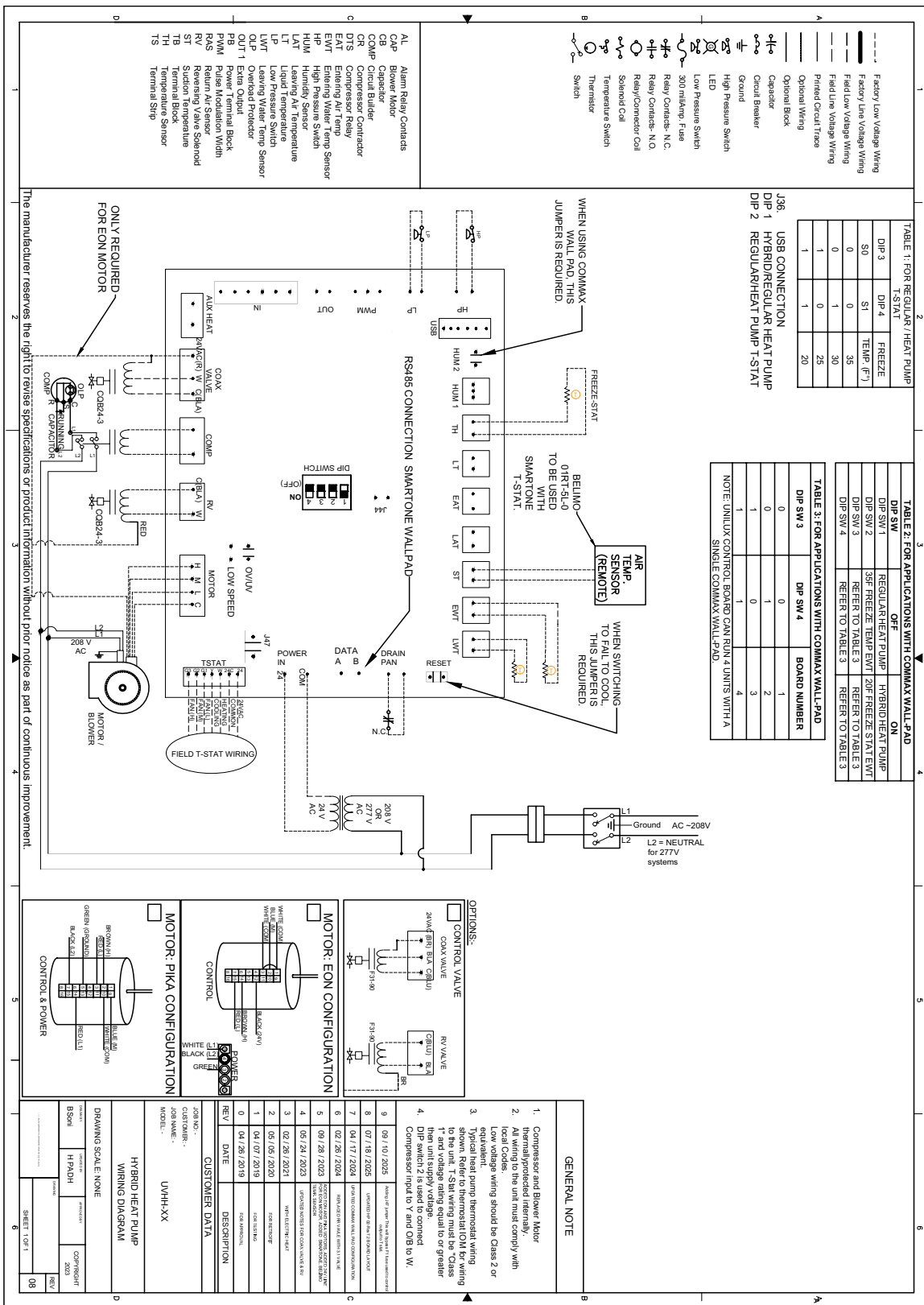

General Operation

UVHPL/UVHPL-G-ERV Wiring Diagram

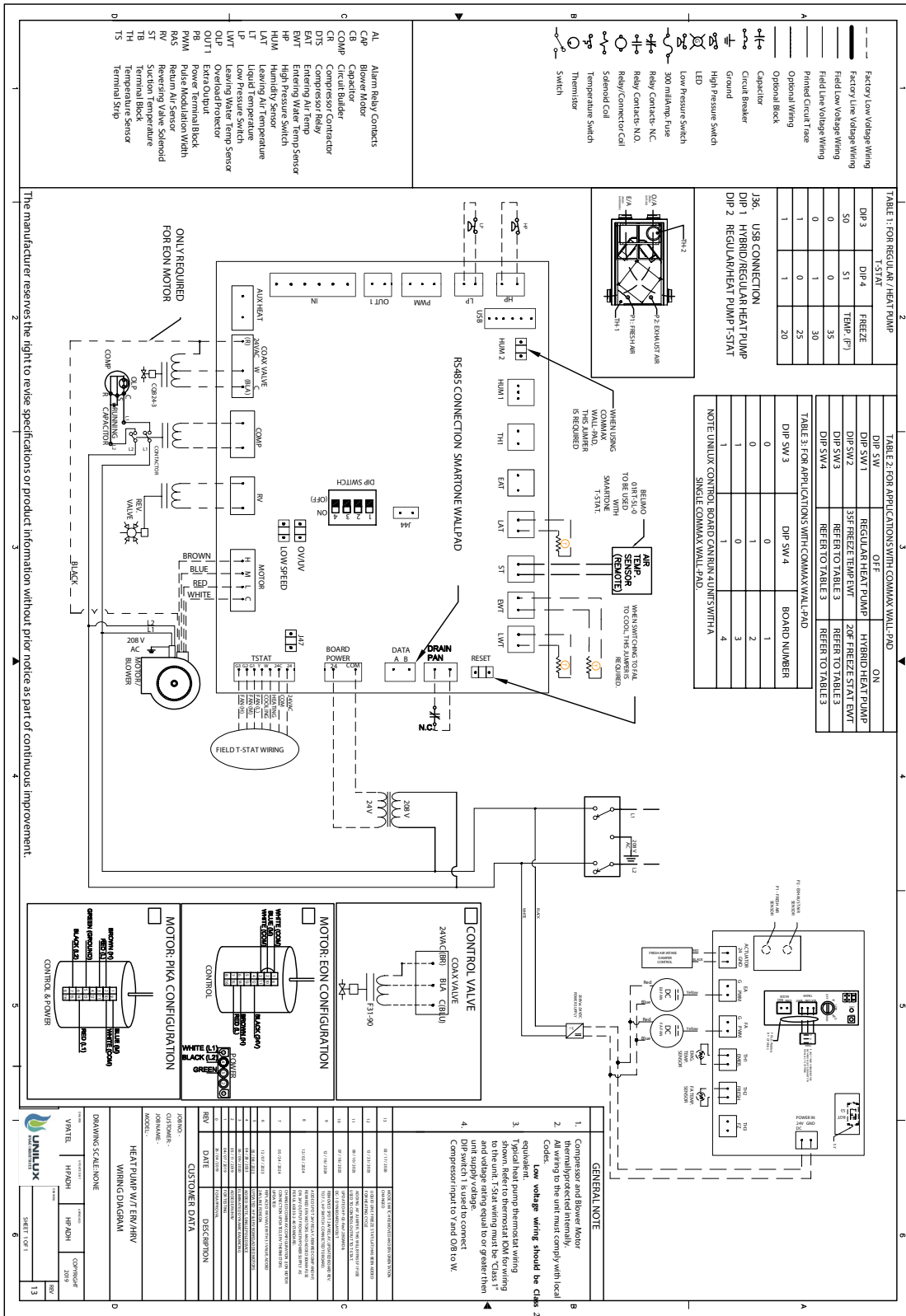

General Operation

UVHHL-ERV Wiring Diagram

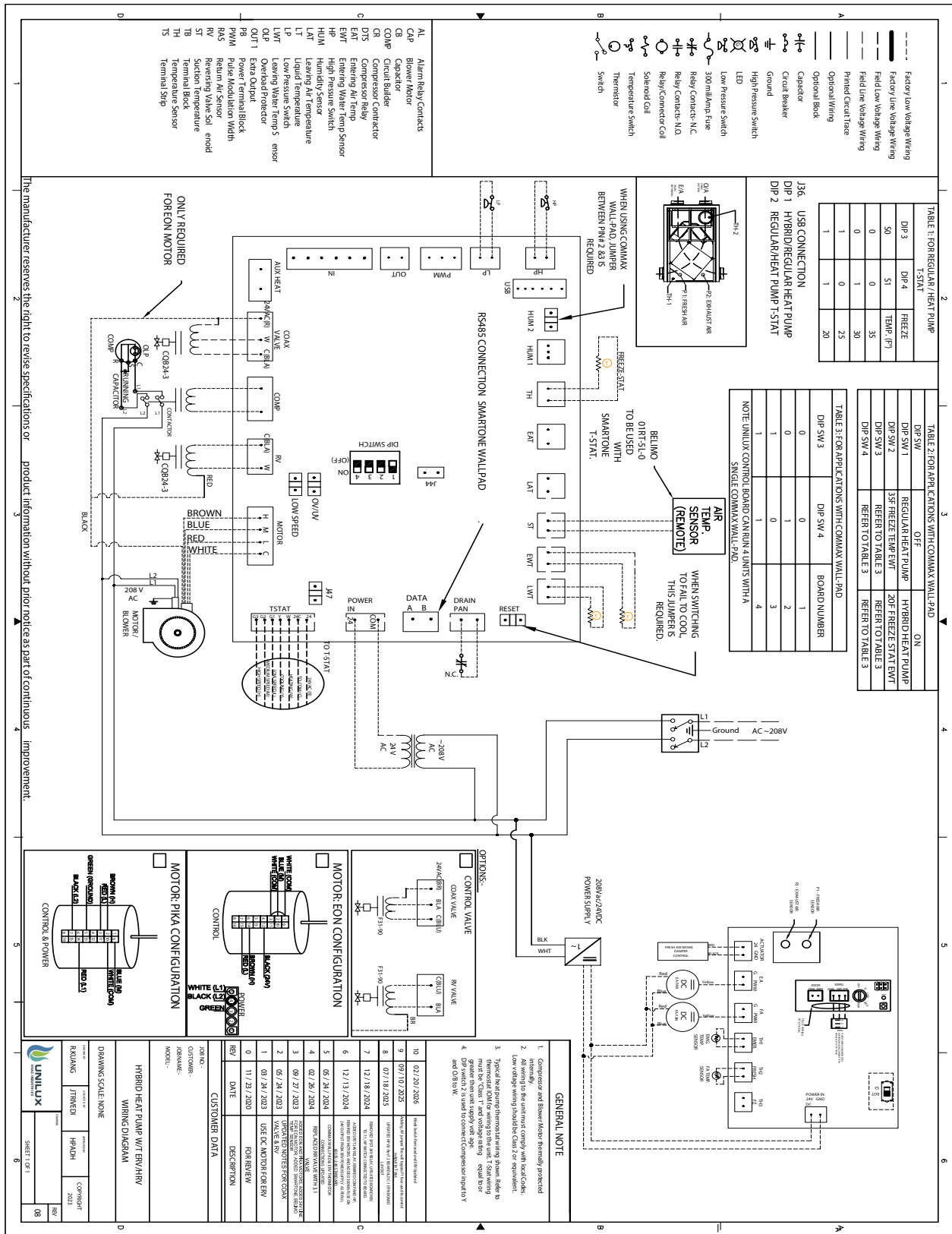

General Operation

Alarms - All Models

High-Pressure (HP) Alarm—Bypass to Latch

- A high-pressure alarm will occur when the HP switch opens.
- Red HP LED is flashing when a HP alarm occurs.
- Alarm will bypass 3 times. System will soft reset each time after HP alarm is set. It will latch on the 4th time which requires a hard reset for normal operation. Delays for compressor short cycle and coax protection will be enabled on each soft reset.

Low-Pressure (LP) By-Pass (Warning)

- If LP switch opens and compressor is running for less than 3 minutes, a LP by-pass warning will be activated. If LP switch closes or compressor is disabled before 3 minutes expires the bypass will be reset.
- Red LP LED will be solid when in LP bypass mode.

Low-Pressure (LP) Alarm Mode—Bypass to Latch

- A LP alarm will occur when the LP switch is open for 3 continuous minutes and the compressor is running.
- The Red LP LED will be flashing when a LP alarm occurs
- Alarm will bypass for 3 times. System will soft reset each time after LP alarm is set. It will latch on the 4th time which requires hard reset for normal operation. Delays for compressor short cycle and coax protection will be enabled on each soft reset.
- **Note:** If the LP switch is open on unit power up a LP alarm is triggered immediately.

When unit is found in low-pressure latched condition, cycle power and operate in cooling mode for one (1) cycle. If unit goes into low-pressure, then there may be a charge or fan issue. If unit goes into high-pressure, there is a water flow issue. Unit should not be operated until the water issue has been identified and resolved. Water flow troubleshooting should only be done in cooling mode. Do not operate in heating mode without proper water flow, as serious damage can occur.

Condensate Overflow (Drain pan) Alarm (Latching Alarm)

- A condensate overflow alarm will occur after 30 seconds if the water sensor input triggers an overflow condition. This is to avoid false tripping.

Water Loop Supply Temperature (EWT) Alarm (Non-Latching Alarm) - UVHPL/UVHPL-G heating and cooling and UVHHL cooling only

- A water loop supply temperature of greater than 110°F/43°C will trigger an EWT alarm.
- A water loop supply temperature of less than 100°F/38°C will reset the EWT alarm.
- The water loop supply temperature is only sensed when the water supply valve is open.
- The EWT LED will be illuminated solid on a EWT alarm.
- If the EWT sensor is open or shorted a EWT alarm is triggered and the Red EWT LED will be blinking.

Water Loop Discharge Temperature (LWT) Alarm (Non-Latching Alarm)

- A water loop discharge temperature of greater than 122°F/50°C will trigger an LWT alarm.
- A water loop discharge temperature of less than 115°F/46°C will reset the LWT alarm.
- The water loop discharge temperature is only sensed when the water supply valve is open.
- The LWT LED will be illuminated solid on a LWT alarm.
- If the LWT sensor is open or shorted a LWT alarm is triggered and the Red LWT LED will be blinking.

Freeze Protection Alarm - UVHPL Only

- A water loop supply temperature (EWT) of less than selected freezing threshold will trigger an EWT alarm (see table below).
- A water loop supply temperature of greater than selected freezing threshold will reset the EWT alarm.
- The water loop supply temperature is only sensed when the water supply valve is open.
- The EWT and LWT LED will be illuminated flashing on a Freeze Protection Alarm.
- Select Freezing Threshold: (Glycol required below 35°F/2°C)

| DIP SW 3 | DIP SW 4 | Temperature |
|----------|----------|-------------|
| OFF | OFF | 35°F / 2°C |
| OFF | ON | 30°F / -2°C |
| ON | OFF | 25°F / -4°C |
| ON | ON | 20°F / -7°C |

Freeze-Stat Protection Alarm - UVHHL Only

- When the Freeze-Stat sensor detects a return air temperature below 41°F/5°C the Freeze-Stat alarm will be triggered.
- The EWT and LWT LED will be illuminated flashing in the event of a Freeze-Stat alarm.

Condenser Freeze Protection - UVHPL (G) Only

- When equipped with this feature, the unit will turn off in heating mode only if the refrigerant temperature going to the condenser falls below based on DIP switch settings.
- The EWT and LWT LED will be illuminated flashing on a Freeze Protection Alarm, and this will stay active until the refrigerant temperature rises above 60°F.
- Alarm will bypass for 3 times. System will soft reset each time after alarm is set. It will latch on the 4th time which requires hard reset for normal operation. Delays for compressor short cycle and coax protection will be enabled on each soft reset.

General Operation

Timers and Interlocks - All Models

Anti-Recycle Timer

Default 7 minutes. Ensures compressor does not restart for 7 minutes.

Fan On Timer

Default 2 minutes.

Water Supply Valve Open Timer (UVHPL Only)

Default 2 minutes. Ensures flow in the Coax before compressor starts.

Fan Off Timer

Default 1 minute. Ensures fan runs for 1 minute after the compressor is turned off.

Water Supply Valve Closed Timer

Default is 3 minutes. Ensures Coax is flushed for 3 minutes after the compressor is turned off.

Changeover Timer

Changeover timer is activated when the system will change from heating to cooling or cooling to heating. In changeover, 3-minute timer will be activated. LP and HP alarm will be bypassed when this timer is activated.

Drain Pan Timer

Drain pan timer is 30 seconds to avoid false shut off. In case of Condensate Overflow Alarm system will bypass alarm for 30 seconds, if that alarm continues after 30 seconds, then the system will shut off.

LED Panel

Heat: Amber LED will be blinking when there is call for heat from thermostat. It will be solid **ON** after satisfying Anti-Recycle, Fan **ON** and Valve Open Timer.

Cool: Blue LED will be blinking when there is call for cool from thermostat. It will be solid **ON** after satisfying Anti-Recycle, Fan **ON** and Valve Open Timer.

LP: 2 stage low pressure LED

1. Solid Red LED: Low pressure detected. System is in bypass mode 3 minutes Low pressure timer activated.
2. Flashing Red LED: Latched low-pressure alarm, alerts after 5 occurrences.

HP: 2 stage high pressure LED

1. Solid Red LED: High pressure detected. System is in bypass mode 3 minutes High pressure timer activated.
2. Flashing Red LED: Latched high-pressure alarm, alerts after 5 occurrences.

DP: Solid Red LED—Latched condenser drain pan alarm.

LWT: Solid Red LED—Leaving water temperature not satisfied.

EWT: Solid Red LED—Entering water temperature not satisfied.

PWR: Solid Red LED—system has power.

Freeze/Freeze-Stat Panels

When entering water temp is less than selected, freezing threshold EWT and LWT LED will be blinking.

Condenser Freeze Protection

EWT + LWT flashing LED - Refrigerant temperature falls below 36°F or lower based on DIP switch settings.

Optional Thermostat

Standard heat and cool call thermostat (DIP SW 2 OFF): In this type of thermostat connect heat call wire to W and cool call wire to Y. (Factory default).

DIP Switch Settings

| DIP SW | OFF | ON |
|----------|--|--|
| DIP SW 1 | UVHPL/UVHPL-G | UVHHL |
| DIP SW 2 | Heat and Cool Call Thermostat | Reversing Valve and Compressor Call Thermostat |
| DIP SW 3 | Refer to Freeze Protection Alarm Table | Refer to Freeze Protection Alarm Table |
| DIP SW 4 | Refer to Freeze Protection Alarm Table | Refer to Freeze Protection Alarm Table |

General Operation

Optional Energy Recovery Ventilator (ERV)

1. The ERV module is off when the main heat pump switch is in the "OFF" position.
2. The outdoor air (OA) and exhaust air (EA) fans operate independently. A built-in pressure sensor dynamically balances the OA and EA fans based on back pressure differences.
3. During normal operation, the EA fan runs continuously at low speed. Low speed can be set to 100%, 75%, 50%, 25% or OFF using the rotary switch. High speed can be manually set in accordance to the following chart using jumpers on the remote switch board.
*Disclaimer: Low speed fan setting is impacted by the high speed jumper setting.
4. When a 20-40-60 timer switch is connected, the ERV switches to high speed for the selected interval. After the timer expires, both fans return to low speed. Dynamic balancing is disabled during timer mode.

Note: When equipped with an integrated ERV module, both the ERV and heat pump will continuously run at low speed.

Setting Fan Speed

Low Speed

Low speed can be set by using the rotary switch on the control board located above the ERV core.

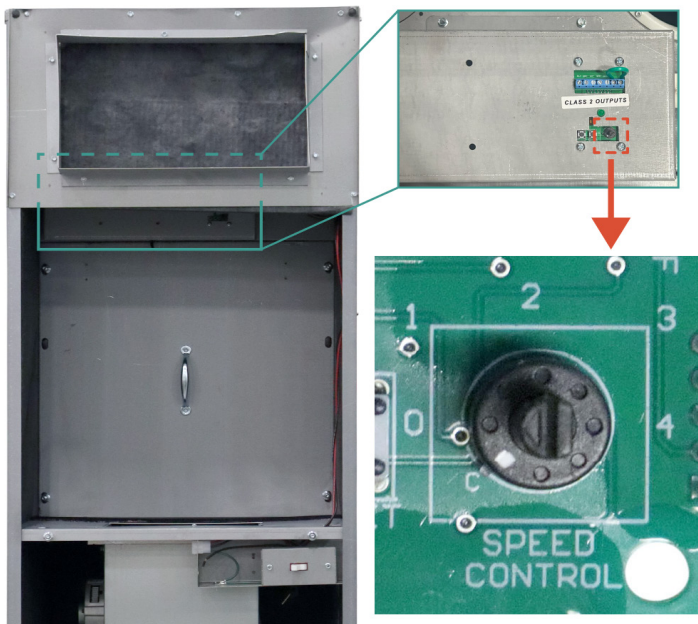

| | | | | | |
|------------------------|-----|----|----|----|-----|
| Rotary Switch Position | 0 | 1 | 2 | 3 | 4 |
| Fan Speed (%) | OFF | 25 | 50 | 75 | 100 |

Note: All setting changes to the ERV speed are saved in event of power outage.

High Speed

High speed can be set by removing the ERV control board cover to access the rear side of the board. A jumper can be placed to reduce the default high speed of 100 CFM, however it will proportionately reduce the speed on the front rotary switch as well. Use the following chart to determine jumper placement for desired CFM.

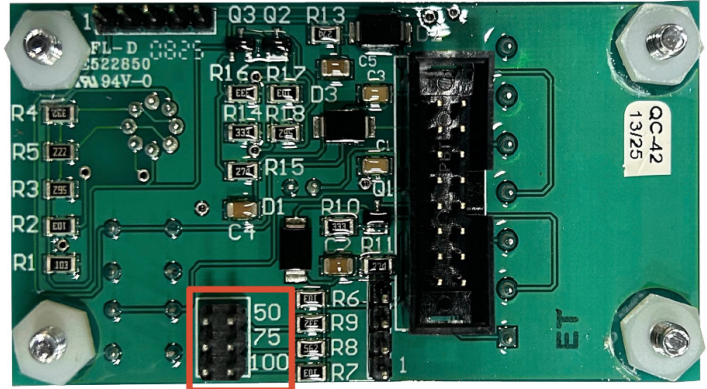

| Rotary Switch Position | No Jumper | Jumper Position 100 | Jumper Position 75 | Jumper Position 50 |
|------------------------|-----------|---------------------|--------------------|--------------------|
| 0 | OFF | OFF | OFF | OFF |
| 1 | 25 | 25 | 25 | 25 |
| 2 | 50 | 50 | 38 | 25 |
| 3 | 75 | 75 | 56 | 38 |
| 4 | 100 | 100 | 75 | 50 |

General Operation

Standard Dynamic Balancing

Unilux HVAC patented dynamic balancing feature minimizes net pressure differences between outside air and recirculation air, thereby reducing drafts within the suite. The dynamic balancing system incorporates a differential pressure sensor symmetrically located in the OA and EA exhaust air streams. The output of the pressure sensor provides a feedback mechanism to independently adjust the OA and EA fan speeds.

This dynamic balancing system samples the air stream pressures periodically, then processes the data and if required, adjusts the OA and EA motor speeds to equalize the pressures. Also, it is noted the system can take up to approximately 5 minutes to fully balance and this time can vary depending on static back pressure.

Defrost Modes

To minimize chance of damage to the heat pump or ERV core, Unilux HVAC has incorporated two temperature sensors. One is located directly inside the OA intake duct flange and the other is located outside of ERV core adjacent to the heat pump blower. When the outside fresh air temperature sensed by the temp sensor reaches pre-set cold temperature limits the Integrated ERV system enters one of the defrost modes described below.

23°F/-5°C Regular Defrost Mode: The Outdoor Air (OA) entering the ERV is continuously monitored by a first temperature sensor and if the OA temperature drops to 23°F/-5°C or colder, the regular defrost protocol is initialized where the damper closes (spring return) to prevent the cold OA from entering the ERV for a defrost period of 15 minutes. During this time, the damper remains closed for 15 minutes regardless of the OA temperature.

The OA fan is on (regardless of the call for Heat/Cool from the thermostat) and warm air from inside the heat pump supply air duct chamber is re-circulated through the ERV core and returned to the heat pump water coil. The EA fan remains ON during this mode. Once the 10 minute defrost cycle is complete, the ERV opens the damper again to allow the fresh air to enter the module once again and the ERV goes back into normal operation for a period of 15 minutes. If after 15 minutes the Fresh Air is still 23°F/-5°C or below, the Defrost Protocol will reinitialize.

Dynamic Balancing works during regular mode of operation and is automatically disabled during energy saving mode and when 20-40-60 timer is ON.

It should be noted that all setting parameters are stored in EEPROM and therefore saved and restored in the event of a power outage.

Emergency Mode: Emergency mode is activated when the second temperature sensor located near to the main blower inlet senses a temperature of 32°F/0°C or colder. This mode will override the above stages of defrost: If the fresh air leaving the ERV core and entering the main blower section is 32°F/0°C or colder, the damper closes (spring return) to prevent more cold air entering the ERV module for a protection period of 90 minutes. The damper stays closed for the full 90 minutes regardless of the OA temperature. During this time warm air from inside the heat pump is re-circulated through the ERV core and heat pump coil. Once the Emergency Freeze Protection cycle is finished, the ERV returns to normal operation.

Information on Servicing

Prior to beginning to work on systems containing flammable refrigerants, safety checks are necessary to ensure the risk of ignition is minimized.

Work shall be undertaken under a controlled procedure so as to minimise the risk of a flammable gas or vapour being present while the work is being performed.

All the maintenance staff and others working in local area shall be instructed on the nature of work being carried out. Work in confined spaces shall be avoided.

The area shall be checked with an appropriate refrigerant detector prior to and during work, to ensure the technician is aware of potentially toxic and flammable atmospheres.

Presence of Fire Extinguisher

While unit is being serviced, it is important to have an appropriate fire extinguishing equipment available to hand. Have a dry powder or CO₂ fire extinguisher adjacent to the charging area.

No Ignition Sources

No person carrying out work in relation to a refrigerating system which involves exposing any pipe work shall use any sources of ignition in such a manner that it may lead to the risk of fire or explosion. All possible ignition sources, including cigarette smoking should be kept sufficiently far away from the site of the installation, repairing, removing and disposal, during which refrigerant can possibly be released to the surrounding spaces. Prior to work taking place, the area of equipment is to be surveyed to make sure that there are no flammable hazards or ignition risks. "No smoking" signs shall be displayed.

Checks to the Refrigerant Equipment

Where electrical components are being changed, they shall be fit for their purpose and to the correct specification. At all times these maintenance guidelines must be followed. If in doubt, consult the manufacturer's technical department for assistance.

The following checks shall be applied to all installations using flammable refrigerants:

- Confirm actual refrigerant charge matched that is on the rating label.
- The ventilation machinery and outlets are operating adequately and are not obstructed.
- Marking to the equipment continues to be visible and legible. Markings and signs that are illegible shall be corrected.

Refrigerant pipe or component shall be installed in a position where they are unlikely to be exposed to any substance which may corrode refrigerant containing components, unless the components are constructed of materials which are inherently resistant to being corroded or are suitably protected against being so corroded.

Checks to Electrical Devices

Repair and maintenance of electrical components shall include initial safety checks and component inspection procedures. If a fault exists that could compromise safety, then no electrical supply shall be connected to the circuit until it is satisfactory dealt with. Initial checks shall include:

- That capacitors are discharged: this shall be done in a safe manner to avoid possibility of sparking.
- That no continuity of earth bonding.

Repairs to the Sealed Components

During repair of sealed components, all electrical supplies shall be disconnected from the equipment being worked upon prior to any removal of sealed covers, etc. Sealed electrical components shall be replaced in case if necessary. Ensure that the apparatus is mounted securely.

Intrinsically Safe Components

Do not apply any permanent inductive or capacitance loads to the circuit without ensuring that this will not exceed the permissible voltage and current permitted for the equipment in use. Intrinsically safe components must be replaced. Replace components only with parts specified by the manufacturer. Other parts may result in the ignition of refrigerant in the atmosphere from a leak.

Cabling

Check that cabling will not be subjected wear, corrosion, excessive pressure, vibration, sharp edges or any other adverse environmental effects. The check shall also take into account the effects of aging or continual vibration from sources such as compressors or fans.

Labelling

Equipment shall be labelled stating that it has been decommissioned and emptied of refrigerant. The label shall be dated and signed. Ensure that there are labels on the equipment stating the equipment contains R454B (A2L) refrigerant.

Heat Pump Maintenance

Important Information - Read Before Performing Any Maintenance

Qualification of Workers

Every working procedure that affects safety means shall only be carried out by competent persons according to the *Competence of Service Personnel* note below.

Checks to the Area

Prior to beginning work on systems containing flammable refrigerants, safety checks are necessary to ensure that the risk of ignition is minimized.

Work Procedure

Work shall be undertaken under a controlled procedure as to minimize the risk of a flammable gas or vapour being present while the work is being performed.

General Work Area

All maintenance staff and others working in the local area shall be instructed on the nature of work being carried out. Work in confined spaces shall be avoided.

Checking for Presence of Refrigerant

The area shall be checked with an appropriate refrigerant detector prior and during work, to ensure the technician is aware of potentially toxic or flammable atmospheres. Ensure that the leak detection equipment being used is suitable for use with all applicable refrigerants i.e. non-sparking, adequately sealed, or intrinsically safe.

Presence of Fire Extinguisher

If any work is to be conducted on the refrigerating equipment or any associated parts, appropriate fire extinguishing equipment shall be available to hand. Have a dry powder or CO₂ fire extinguisher adjacent to the charging area.

No Ignition Sources

No person carrying out work in relation to a refrigerating system which involves exposing any pipe work shall use any sources of ignition in such a manner that it may lead to the risk of fire or explosion. All possible ignition sources, including cigarette smoking should be kept sufficiently far away from the site of the installation, repairing, removing and disposal, during which refrigerant can possibly be released to the surrounding spaces. Prior to work taking place, the area of equipment is to be surveyed to make sure that there are no flammable hazards or ignition risks. "No smoking" signs shall be displayed.

Note: Information of procedures additional to usual information for refrigerating appliance installation, repair, maintenance, and decommission procedures is required when an appliance with flammable refrigerants is affected. The training of these procedures is carried out by national training organizations that are accredited to teach the relevant national competency standards that may be set in legislation.

All maintenance should be done by a certified HVAC technician adhering to the following requirements.

Competence of Service Personnel

Information and Training: the training should include the substance of the following:

- Information about the explosion potential of flammable refrigerants to show that flammables may be dangerous when handled without care.
- Information about potential ignition sources, especially those that are not obvious, such as lighters, light switches, vacuum cleaners, electric heaters.
- Information about the different safety concepts:
 - Unventilated** - Safety of the appliance does not depend on ventilation of the housing. Switching off the appliance or opening the housing has no significant effect on the safety.

Nevertheless, it is possible that leaking refrigerant may accumulate inside the enclosure and flammable atmosphere will be released when the enclosure is opened.

Ventilated Enclosure - Safety of the appliance depends on ventilation of the housing. Switching off the appliance or opening the enclosure has a significant effect on the safety. Care should be taken to ensure sufficient ventilation before.

Ventilated Room - Safety of the appliance depends on the ventilation of the room. Switching off the appliance or opening the housing has no significant effect on the safety. The ventilation of the room shall not be switched off during repair procedures.

Heat Pump Maintenance

Proper periodical heat pump maintenance will ensure the best unit performance. Before starting any maintenance work, ensure the disconnect switch on the unit is off and the circuit breaker on the fuse panel is in the OFF position. Don't run the unit without filters or during any temporary construction that could clog the air filter or air coil. Don't use any acid-based cleaning solutions on the air coil or any refrigerant components. **Check safety equipment before putting into service.**

General Maintenance and Repair

Heat pump chassis shall be repaired outside or in a workshop specially equipped for servicing units with flammable refrigerants. Ensure sufficient ventilation at the repair place. Be aware that malfunction of the equipment may be caused by refrigerant loss and a refrigerant leak is possible. Discharge capacitors in a way that won't cause a spark. The standard procedure to short circuit the capacitor terminals usually creates sparks. Reassemble sealed enclosures accurately. If seals are worn, replace them.

When brazing is required, the following procedures shall be carried out in the following order:

1. Safely remove the refrigerant following local and national regulations. If the recovery is not required by national regulations, drain the refrigerant to the outside. Take care that drained refrigerant will not cause any danger. In doubt, one person should guard the outlet. Take special care that drained refrigerant will not float back into the building.
2. Purge the refrigerant circuit with oxygen free nitrogen.
3. Evacuate the refrigerant circuit.
4. Remove parts to be replaced by cutting or brazing.
5. Purge the braze point with nitrogen during the brazing procedure required for repair.
6. Carry out a leak test before charging with refrigerant.

Monthly Maintenance

- Vacuum dust from unit air grilles and surrounding coil area with a soft bristle brush attachment as required.
- Every month visibly inspect the unit for any signs of water leaks, or water damage around the floor or surrounding drywall.

Quarterly Maintenance

- Visibly inspect the air filter monthly for dirt and clogging. Replace as required with a quality filter. Pleated filters rated between MERV 8 to MERV 10 are preferable as they will provide optimal filtration. Filters with a rating higher than MERV 10 may reduce airflow and increase fan power consumption and unit performance.
- If heat pump features an integrated HRV/ERV system, visibly inspect the foam air filters monthly for dirt and clogging. Wash as required in lukewarm water and mild soap solution. Rinse well and shake out excess water. Let filters air dry before reinstalling.
- Inspect condensate drain pan every three months for signs of stagnant water, mineral buildup, and microbial growth.

Clean the drain pan with mild soapy water as required to prevent condensate hose blockages and microbial growth.

- Check valves and hoses for signs of fluid leaks, deterioration, or cracking.

Half-yearly Maintenance

- Check condensate fluid flow to ensure adequate drainage and test for signs of looming blockages. A technician must check that the condensate switch alarm is operating correctly. Alarm trips whenever water level rises above sensor threshold and locks unit operation.
- Visibly inspect the air coil for signs of dirt accumulation between aluminum fins. First vacuum and then use a coil-cleaning agent if required. Don't use any cleaning solutions that contain acid, including acetic acid (vinegar). Damage to the air coil may occur resulting in possible refrigerant leaks.

Annual Maintenance

- Perform an annual maintenance inspection of the fan and blower motor assembly. All units come with permanently lubricated fan motors and don't require any lubrication of fan motors. Clean up any dirt or debris that may have accumulated.
- If heat pump features an integrated HRV/ERV system, perform an annual maintenance inspection of the core assembly. Clean up any dirt or debris that may have accumulated.
- Visibly inspect the electrical box for signs of component damage due to overheating or poor electrical contact.

| Filter Sizes | |
|---|-----------------------------|
| Model | Filter Size |
| UVHP02-04L (G) / UVHH02-04L (G) | 14" x 25" x 1" |
| UVHP05-06L (G) / UVHP02-06L ERV (G) / UVHH02-04L ERV | 16" x 25" x 1" |
| UVHP08-12L (G) / UVHP08-12L ERV (G) / UVHH05-12L / UVHH05-12L ERV | 16" x 16" x 1" (two per) |

Warranty Information

Unilux HVAC warrants that its products are free from defects in parts and factory workmanship for a period of 24 months from start-up date. Start-up must be performed by a Unilux authorized technician. Products or consumable components such as air filters are not covered. Components manufactured by third parties bear the warranty of their manufacturer. Refrigerant gas is not covered.

The details of the warranty are as following:

(A) In the event that a part is deemed defective, the user must immediately inform Unilux HVAC in writing who will at its option furnish new or factory re-manufactured part at no cost to the user ex-factory. The user must return the defective part to Unilux HVAC within 30 days upon receipt of the replacement for evaluation.

(B) The warranty does not cover any costs of troubleshooting, shipment, installation or maintenance. The warranty also does not apply to the following situations: any damage or defect due to mishandling; improper storage; misuse; installation, commissioning, operation and maintenance contrary to Unilux HVAC's drawing, descriptive manual or recommendation; wrong supply of electricity, water or drain; improper repair; tamper or alteration; negligence; accident; normal wear; or any cause beyond the control of Unilux HVAC.

(C) The original warranty period does not change in the event of part replacement from Unilux HVAC.

(D) The warranty is issued exclusively to the original end-user of record at the time of manufacture and is not transferable.

(E) The provisions of the foregoing warranty are in lieu of any other warranty, whether express or implied, written or oral (including any warranty of merchantability or fitness for a particular purpose or of title or non-infringement). Unilux HVAC's liability arising out of the manufacturer, sale, or supplying of the products or their use or disposition, whether based upon warranty, contract, tort, or otherwise, shall not exceed the actual purchase price paid by the distributor for the product(s). In no event shall Unilux HVAC be liable to the distributor or any other person or entity for special, incidental, consequential or punitive damages (including, but not limited to loss of profits, loss of data, or loss of use damages) arising out of the manufacture, sale, or supplying of the products, even if Unilux HVAC has been advised of the possibility of such damages or losses.

Product Line: _____ User Name: _____

Model Number: _____ User Address: _____

Serial Number: _____

Shipping Date: _____

Warranty Expiry Date: _____ Fax Number: _____

Please complete the above information, along with copy of site-completed Commissioning Checklist and return to:

7930 Huntington Road Unit A, Woodbridge, ON L4H 4M8 • Phone: 905.851.3981 • Email: service@uniluxhvac.com